



Polygon Tooling Series

Polygon-Werkzeughalter für Dreh-Fräszentren
Polygon Toolholders for Millturn-Machines

ISO 26623-1
JIS B 6066-1



Die perfekte Schnittstelle für Dreh-Fräszentren und Drehmaschinen
the perfect interface for lathes and turning-milling centres

made by  **NT TOOL**
www.nttooleurope.com

Die Polygon-Form nimmt Torsions- und Biegemomente sehr gut auf. Dem Anwender steht beim Drehen damit ein äußerst präzises und schnelles Werkzeugwechselsystem in den Größen C3, C4, C5 und C6 zur Verfügung, das wir nach ISO 26623 fertigen.

The polygonal form can easily accommodate torsional moments and bending moments. As such, users have access to an extremely high-precision and fast tool-change system in the sizes C3, C4, C5 and C6 and C8, which we manufacture according to ISO 26623.

ISO 26623-1
JIS B 6066-1



Merkmale | Features

Höchste Steifigkeit
High rigidity

Große Stabilität und Steifigkeit aufgrund hoher Biegefestigkeit und Drehmomentübertragung.

The ISO standard dual-contact Polygon offers high stability and increases rigidity.

Höchste Wiederholgenauigkeit
High repeat-mounting accuracy.

Der Polygonschaft garantiert höchste Wiederholgenauigkeit.

Polygon shank ensures excellent accuracy in rotational direction.

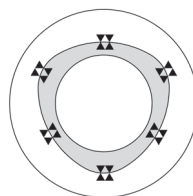

Auswahl | Selection

NT bietet eine große Auswahl an Polygon-Werkzeugaufnahmen:
NT offers a wide range of Polygon-Tooling:

- Hochgenauigkeits-Spannzangenfutter
- Hochleistungs-Kraftspannfutter
- Bohrstangenhalter
- Halter für Wendepaltenbohrer
- Power-Dehnspannfutter
- Schrumpfaufnahmen
- SynchroFit-Gewindeschneidfutter
- Aufsteck-Fräsdorne
- High Precision Collet Chucks
- High Performance Milling Chucks
- Boring Bar Holders
- Toolholders for Drill
- Power Hydro Chucks
- Shrink Fit Chucks
- SynchroFit Tap Holders
- Face Mill Arbors

Polygon-Rohlinge | Exterior taper blanks

Wir fertigen Rohlinge mit Polygonschaft nach Kundenvorgabe

We manufacture blanks with the polygon taper shank to the customer's specifications.

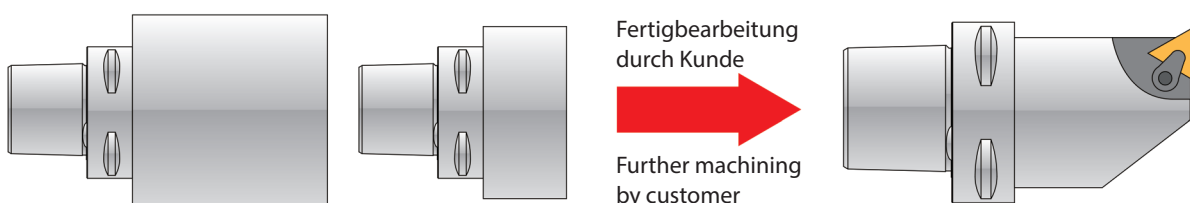

Inhalt | Content

Halter für negative Schneidplatten mit D-Klemmung Holders for negative inserts with D-Clamping

DCLN P. 6

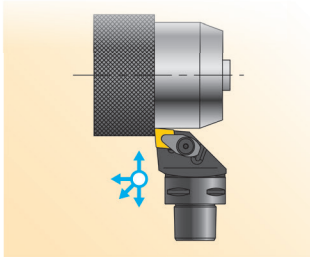

DDJN P. 6

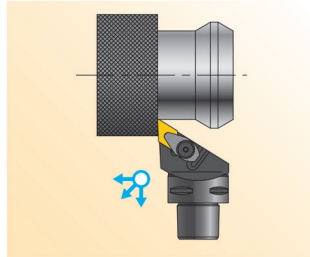

DDUN P. 7

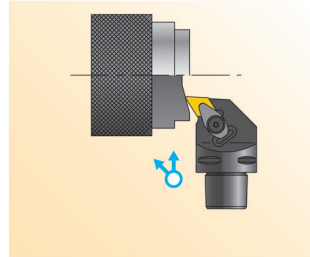

DDHN P. 7

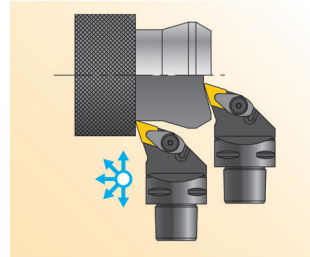

DSSN P. 8

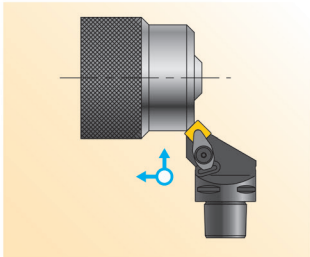

DWLN P. 8

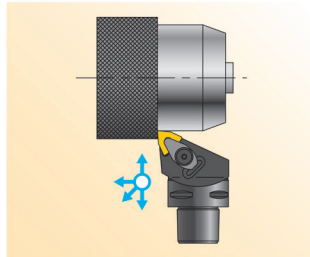

DSDN P. 9

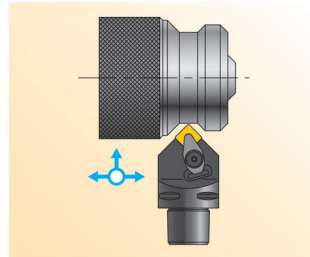

DSKN P. 9

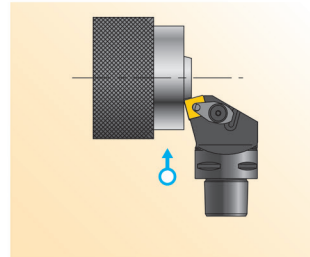

Halter für negative Schneidplatten mit P-Klemmung Holders for negative inserts with P-Clamping

PCLN P. 10

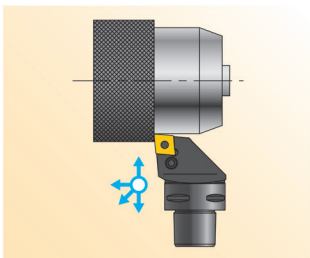

PDJN P. 10

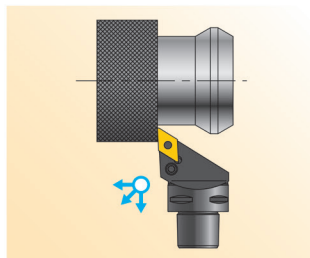

PDUN P. 11

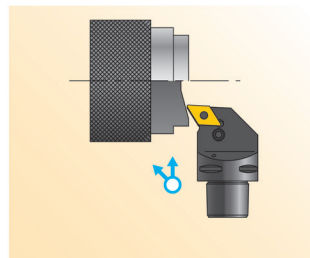

PDHN P. 11

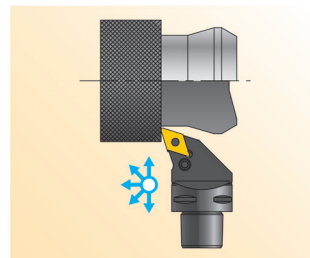

PSSN P. 12

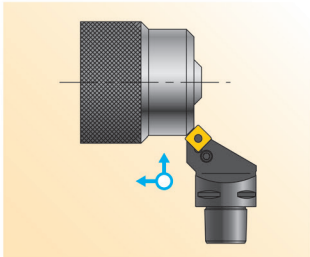

PSDN P. 12

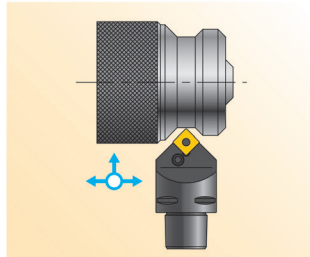

PSKN P. 13

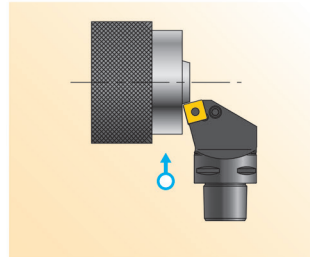

Halter für positive Schneidplatten mit S-Klemmung
 Holders for positive inserts with S-Clamping

SVJB P. 14

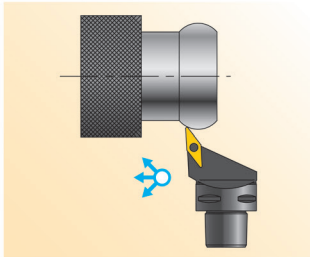

SVQB P. 14

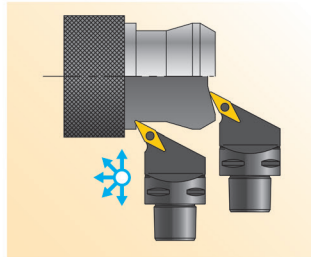

SVVB P. 15

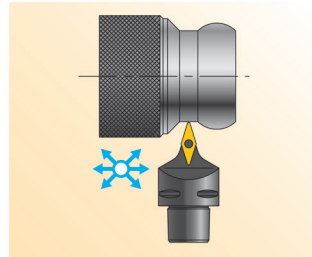

Halter für die Innenbearbeitung mit D-Klemmung
 Holders for internal cutting with D-Clamping

DCLN P. 16

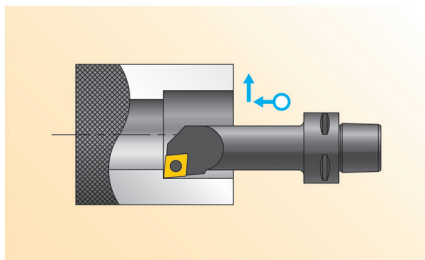

DDUN P. 16

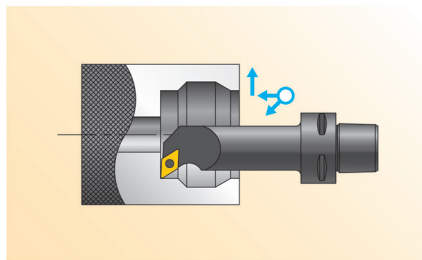

Halter für die Innenbearbeitung mit S-Klemmung
 Holders for internal cutting with S-Clamping

SVQB P. 17

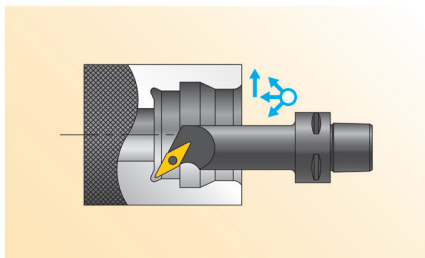

SDZC P. 17

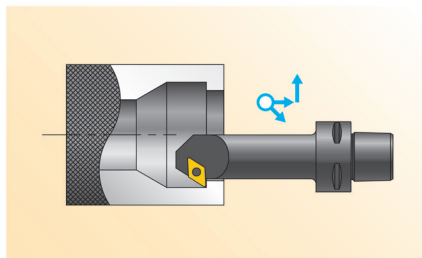

STFC P. 18

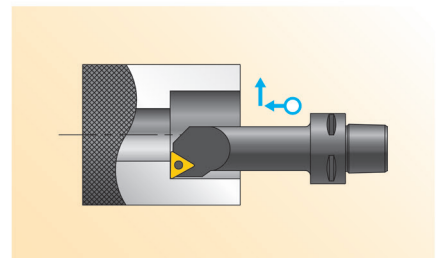

■ **Bestellbeispiel** | Ordering Example

C4 - DCLN R - 27 050 - 12

Schaftgröße
Shank Size

Halter
Holder

Vorschubrichtung
Hand

Maß
Holder size

Länge
Length

Schneidkantenlänge
Insert size



C3~C6 NC tooling

Spannzangenfutter **HDC-A** ... P. 20
Collet Holder

Für die hochpräzise Bohrungsbearbeitung
Useable for high precision holemaking

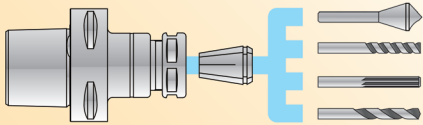

Bohrstangenhalter **TSB** ... P. 22
For Boring bar

für Bohrstangen mit Fläche
for boring bars with flat

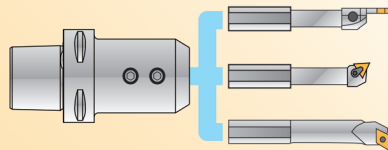

für WP-Bohrer **TSD** ... P. 23
For Drill

für Wendeplattenbohrer
for drills with inserts

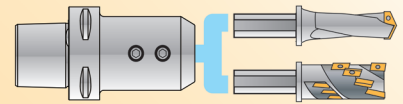

C5, C6 NC tooling

Hochleistungs-Kraftspannfutter **CT-SA** ... P. 24
High Performance Milling Chuck

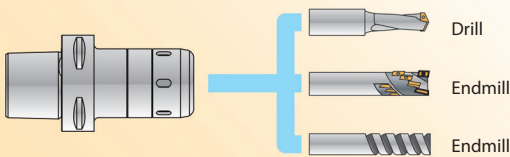

Dehnspannfutter superschlank **PHC-SA** ... P. 25
Slim Hydro Chuck

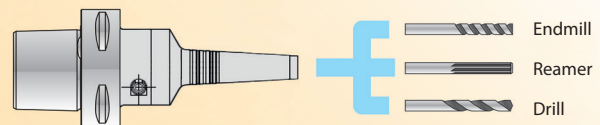

Power Hydro-Dehnspannfutter **PHC-A** ... P. 26
Power Hydro Chuck

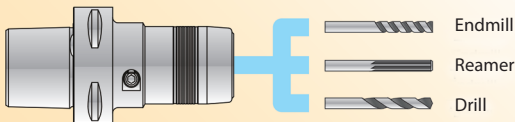

DIN-Schrumpffutter **SRD** ... P. 28
DIN Shrink Fit Chuck

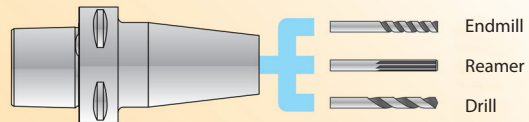

Aufsteck-Fräsdorn cool series* **FMH-A** ... P. 29
Face Mill Arbor cool series*



Multibore Grundaufnahmen ... P. 30
Multibore Master Shank

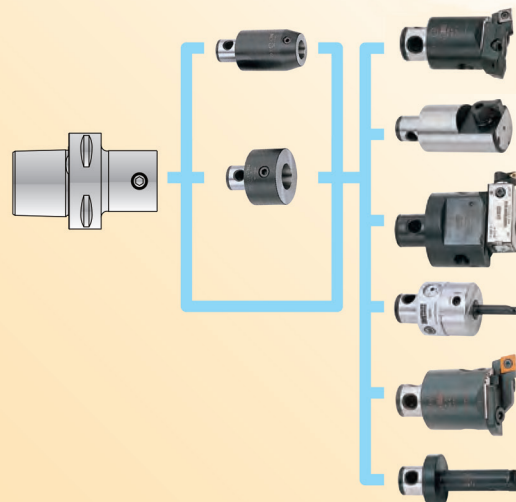

SynchroFit-Gewindeschneidfutter **SFH-S** ... P. 31
SynchroFit Tap Holder

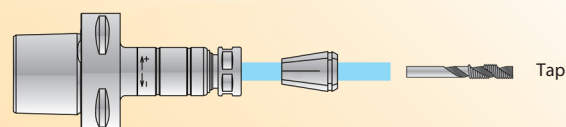

DCLN

■ Zum allgemeinen Drehen, Kopieren und Plandrehen | For General Machining



Abb. Rechtsausführung | Right-hand drawing shown

Halter Holder	F	L	D1	Kg	Plattentyp Insert	Ersatzteile Accessory *						
						Unterlage Sheet	Spannschr. für Unterl. Sheet Stopper Pin	Spannpratze Clamp Bridge	Druckfeder Spring	Spannschraube Clamp Screw	Schlüssel Wrench	
C3 -DCLN R -22040 - 09	22	40	70		CNM○	0903○○	LLSCN3T3	LLP23	DCK2211	DCS2	DC0520T	TKY15F
	L -22040 - 09	22	40	70	CNG○							
C4 -DCLN R -27050 - 12	27	50	110		CNM○	1204○○	LLSCN42	LLP14	DCK2613	DCS1	DC0621T	TKY20F
	L -27050 - 12	27	50	110	CNG○							
C5 -DCLN R -35060 - 12	35	60	110		CNM○	1204○○	LLSCN42	LLP14	DCK2613	DCS1	DC0621T	TKY20F
	L -35060 - 12	35	60	110	CNG○							
C6 -DCLN R -45065 - 12	45	65	110		CNM○	1204○○	LLSCN42	LLP14	DCK2613	DCS1	DC0621T	TKY20F
	L -45065 - 12	45	65	110	CNG○							

*Im Lieferumfang enthalten | included in delivery

DDJN

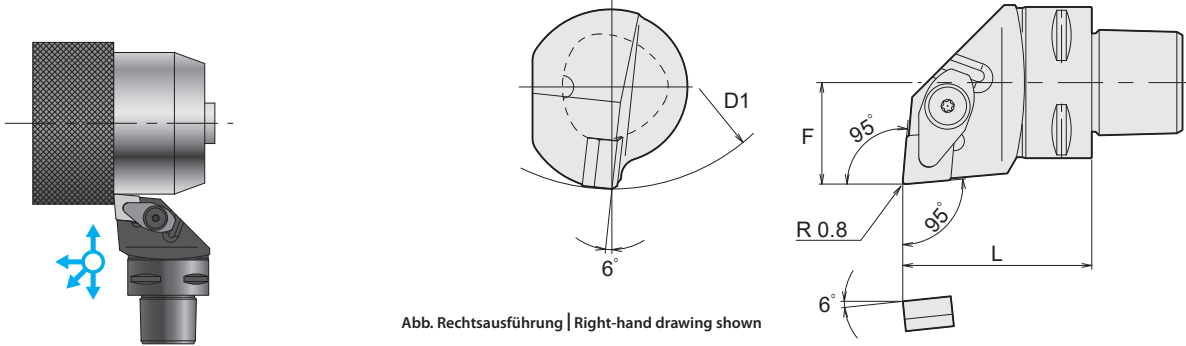
■ Zum Kopier- und Längsdrehen | Profile Machining



Abb. Rechtsausführung | Right-hand drawing shown

Halter Holder	F	L	D1	Kg	Plattentyp Insert	Ersatzteile Accessory *						
						Unterlage Sheet	Spannschr. für Unterl. Sheet Stopper Pin	Spannpratze Clamp Bridge	Druckfeder Spring	Spannschraube Clamp Screw	Schlüssel Wrench	
C3 -DDJN R -22045 - 11	22	45	70		DNM○	1104○○	LLSDN32	LLP23	DCK2211	DCS2	DC0520T	TKY15F
	L -22045 - 11	22	45	70	DNG○							
C4 -DDJN R -27055 - 15	27	55	110		DNM○	1504○○	LLSDN43	LLP24	DCK2613	DCS1	DC0621T	TKY20F
	L -27055 - 15	27	55	110	DNG○							
C5 -DDJN R -35060 - 15	35	60	110		DNM○	1504○○	LLSDN43	LLP24	DCK2613	DCS1	DC0621T	TKY20F
	L -35060 - 15	35	60	110	DNG○							
C6 -DDJN R -45065 - 15	45	65	110		DNM○	1504○○	LLSDN43	LLP24	DCK2613	DCS1	DC0621T	TKY20F
	L -45065 - 15	45	65	110	DNG○							

*Im Lieferumfang enthalten | included in delivery

DDUN

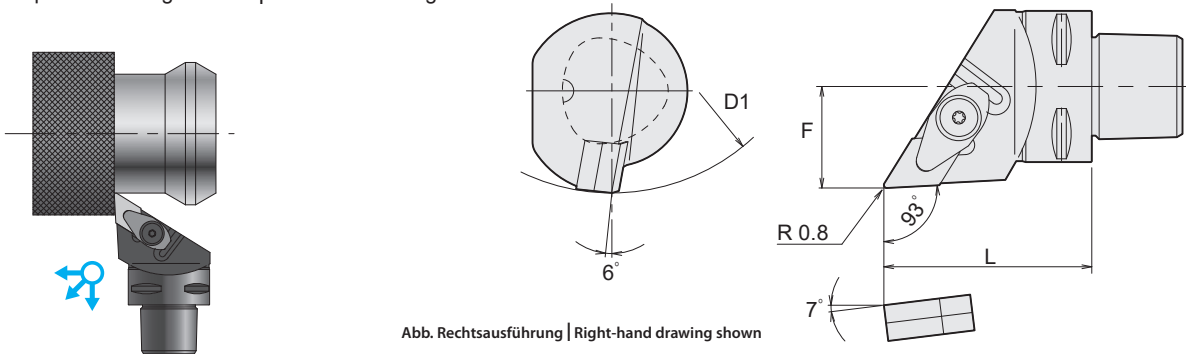
■ Zum Kopier- und Längsdrehen | For Edge · Profile Machining



Abb. Rechtsausführung | Right-hand drawing shown

Halter Holder	F	L	D1	Kg	Plattentyp Insert	Ersatzteile Accessory *						
						Unterlage Sheet	Spannschr. für Unterl. Sheet Stopper Pin	Spannpratze Clamp Bridge	Druckfeder Spring	Spannschraube Clamp Screw	Schlüssel Wrench	
C4 -DDUN R -27050 - 15	27	50	110		DNMO DNGO	1504	LLSDN43	LLP24	DCK2613	DCS1	DC0621T	TKY20F
L -27050 - 15	27	50	110									
C5 -DDUN R -35060 - 15	35	60	110									
L -35060 - 15	35	60	110									
C6 -DDUN R -45065 - 15	45	65	110									
L -45065 - 15	45	65	110									

*Im Lieferumfang enthalten | included in delivery

DDHN

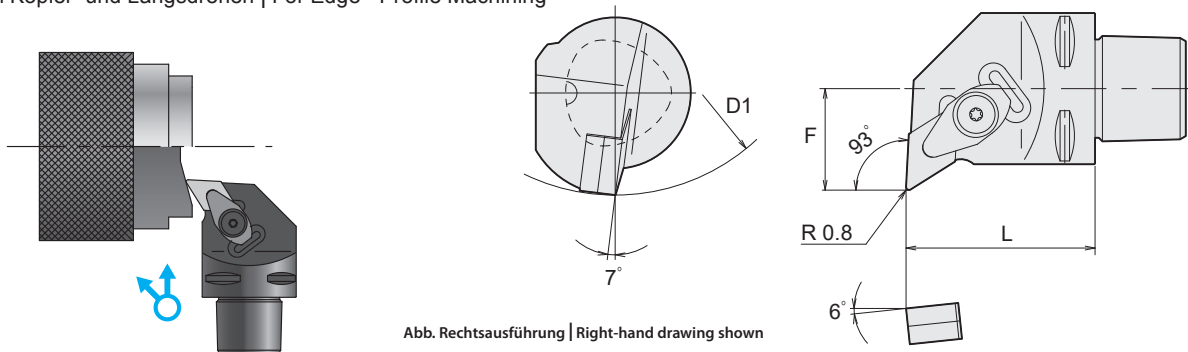
■ Zum Kopier- und Längsdrehen | For Edge · Profile Machining



Abb. Rechtsausführung | Right-hand drawing shown

Halter Holder	F	L	D1	Kg	Insert	Ersatzteile Accessory *						
						Unterlage Sheet	Spannschr. für Unterl. Sheet Stopper Pin	Spannpratze Clamp Bridge	Druckfeder Spring	Spannschraube Clamp Screw	Schlüssel Wrench	
C4 -DDHN R -27055 - 15	27	55	110		DNMO DNGO	1504	LLSDN43	LLP24	DCK2613	DCS1	DC0621T	TKY20F
L -27055 - 15	27	55	110									
C5 -DDHN R -35060 - 15	35	60	110									
L -35060 - 15	35	60	110									
C6 -DDHN R -45065 - 15	45	65	110									
L -45065 - 15	45	65	110									

*Im Lieferumfang enthalten | included in delivery

DSSN

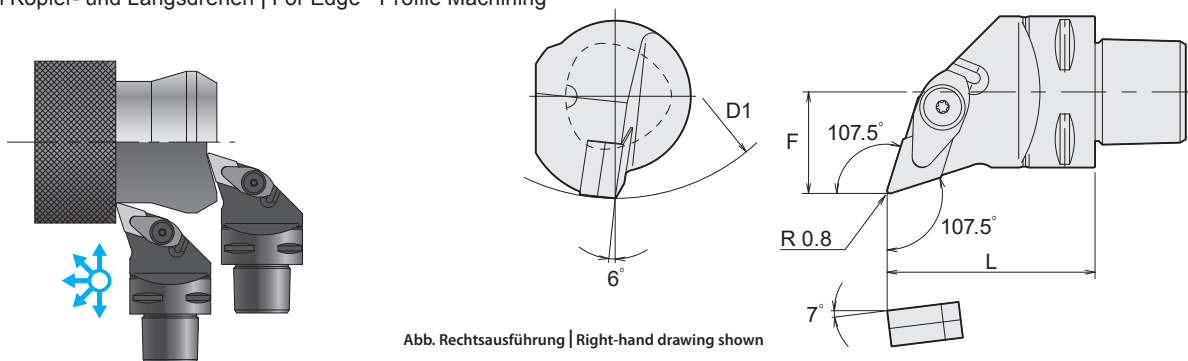
■ Zum Längs- und Plandrehen | For Chamfering · Exterior Machining



Abb. Rechtsausführung | Right-hand drawing shown

Halter Holder	F	L	D1	Kg	Plattentyp Insert	Ersatzteile Accessory *						
						Unterlage Sheet	Spannschr. für Unterl. Sheet Stopper Pin	Spannpratze Clamp Bridge	Druckfeder Spring	Spannschraube Clamp Screw	Schlüssel Wrench	
C3 -DSSN R -22045 - 12	22	45	90		SNMO SNGO	1204	LLSSN42	LLP14	DCK2613	DCS1	DC0621T	TKY20F
L -22045 - 12	22	45	90									
C4 -DSSN R -27045 - 12	27	45	110									
L -27045 - 12	27	45	110									
C5 -DSSN R -35052 - 12	35	52	110									
L -35052 - 12	35	52	110									
C6 -DSSN R -45056 - 12	45	56	110									
L -45056 - 12	45	56	110									

*Im Lieferumfang enthalten | included in delivery

DWLN

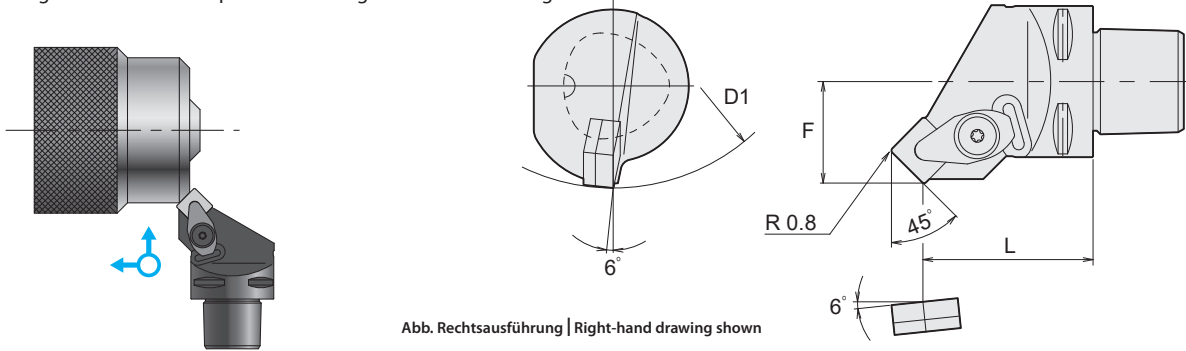
■ Zum allgemeinen Drehen, Kopieren und Plandrehen | For General Machining



Abb. Rechtsausführung | Right-hand drawing shown

Halter Holder	F	L	D1	Kg	Plattentyp Insert	Ersatzteile Accessory *						
						Unterlage Sheet	Spannschr. für Unterl. Sheet Stopper Pin	Spannpratze Clamp Bridge	Druckfeder Spring	Spannschraube Clamp Screw	Schlüssel Wrench	
C3 -DWLN R -22040 - 06	22	40	70		WNMO WNGO	06T3	LLSWN3T3	LLP23	DCK2211	DCS2	DC0520T	TKY15F
L -22040 - 06	22	40	70									
C4 -DWLN R -27050 - 08	27	50	110									
L -27050 - 08	27	50	110									
C5 -DWLN R -35060 - 08	35	60	110		WNMO WNGO	0804	LLSWN42	LLP14	DCK2613	DCS1	DC0621T	TKY20F
L -35060 - 08	35	60	110									
C6 -DWLN R -45065 - 08	45	65	110									
L -45065 - 08	45	65	110									

*Im Lieferumfang enthalten | included in delivery

DSDN

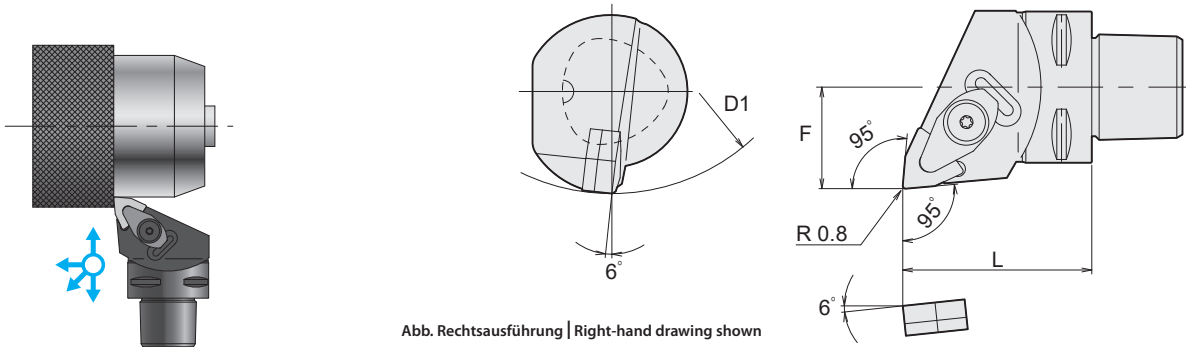
■ Zum Kontur- und Längsdrehen | For Chamfering · Exterior Profile Machining

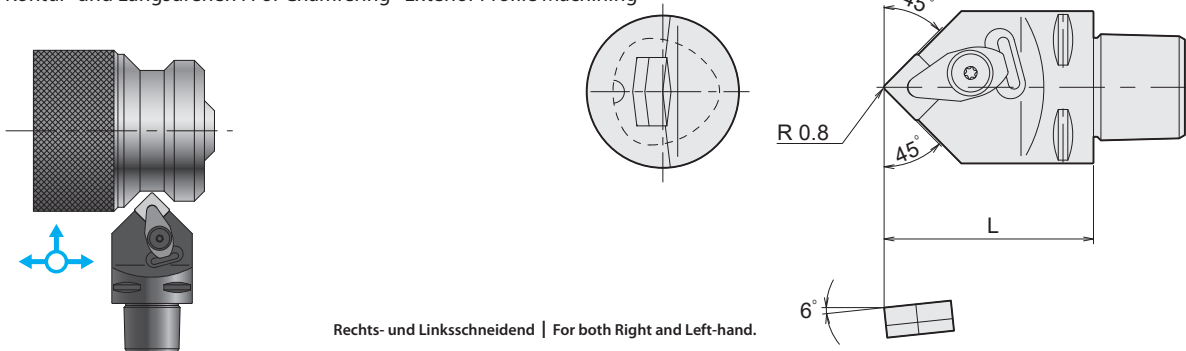

Rechts- und Linksschneidend | For both Right and Left-hand.

Halter Holder	L	Kg	Plattentyp Insert		Ersatzteile			Accessory *		
					Unterlage Sheet	Spannschr. für Unterl. Sheet Stopper Pin	Spannpratze Clamp Bridge	Druckfeder Spring	Spannschraube Clamp Screw	Schlüssel Wrench
C3 -DSDN N -00053 - 12	53		SNM○ SNG○	1204○○	LLSSN42	LLP14	DCK2613	DCS1	DC0621T	TKY20F
C4 -DSDN N -00055 - 12	55									
C5 -DSDN N -00060 - 12	60									
C6 -DSDN N -00065 - 12	65									

*Im Lieferumfang enthalten | included in delivery

DSKN

■ Zum Plandrehen | For Edge Pull Machining



Abb. Rechtsausführung | Right-hand drawing shown

Halter Holder	F	L	D1	Kg	Plattentyp Insert		Ersatzteile Accessory *					
							Unterlage Sheet	Spannschr. für Unterl. Sheet Stopper Pin	Spannpratze Clamp Bridge	Druckfeder Spring	Spannschraube Clamp Screw	Schlüssel Wrench
C4 -DSKN R -27050 - 12	27	50	110		SNM○ SNG○	1204○○	LLSSN42	LLP14	DCK2613	DCS1	DC0621T	TKY20F
L -27050 - 12	27	50	110									
C5 -DSKN R -35060 - 12	35	60	110									
L -35060 - 12	35	60	110									
C6 -DSKN R -45065 - 12	45	65	110									
L -45065 - 12	45	65	110									

*Im Lieferumfang enthalten | included in delivery

PCLN

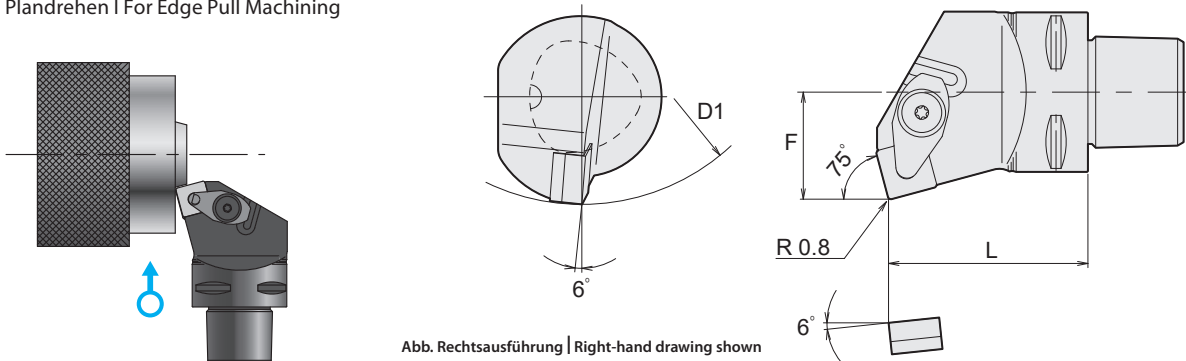
■ Zum allgemeinen Drehen, Kopieren und Plandrehen | For General Machining



Abb. Rechtsausführung | Right-hand drawing shown

Halter Holder	F	L	D1	Kg	Plattentyp Insert	Ersatzteile Accessory *				
						Unterlage Sheet	Spannschr. für Unterl. Sheet Stopper Pin	Hebel Clamp Lever	Spannschraube Clamp Screw	Schlüssel Wrench
C3 -PCLN R -22040 - 09	22	40	70		0903○○	LLSCN3T3	LLP13	LLCL13	LLCS106	HKY25R
L -22040 - 09	22	40	70							
C4 -PCLN R -27050 - 12	27	50	110		CNMO CNGO	1204○○	LLP14	LLCL14	LLCS108	HKY30F
L -27050 - 12	27	50	110							
C5 -PCLN R -35060 - 12	35	60	110		CNMO CNGO	1204○○	LLP14	LLCL14	LLCS108	HKY30F
L -35060 - 12	35	60	110							
C6 -PCLN R -45065 - 12	45	65	110		CNMO CNGO	1204○○	LLP14	LLCL14	LLCS108	HKY30F
L -45065 - 12	45	65	110							

*Im Lieferumfang enthalten | included in delivery

PDJN

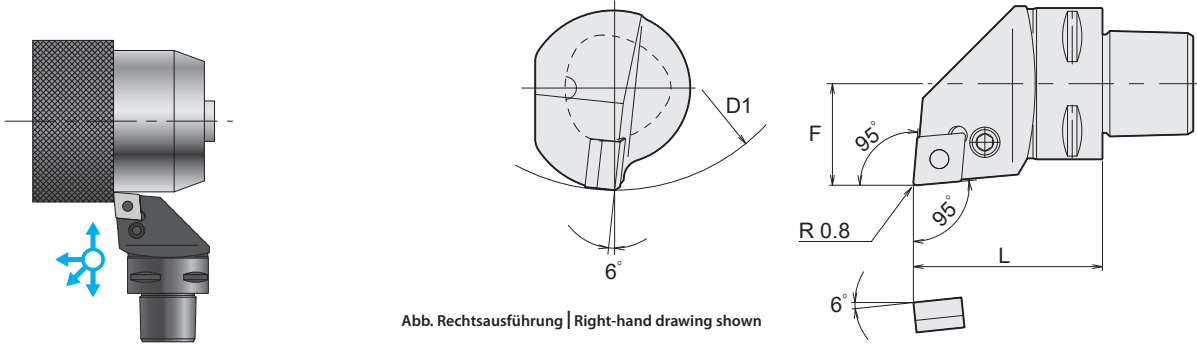
■ Zum Kopier-- und Längsdrehen | Profile Machining



Abb. Rechtsausführung | Right-hand drawing shown

Halter Holder	F	L	D1	Kg	Plattentyp Insert	Ersatzteile Accessory *					
						Unterlage Sheet	Spannschr. für Unterl. Sheet Stopper Pin	Hebel Clamp Lever	Spannschraube Clamp Screw	Schlüssel Wrench	
C4 -PDJN R -27055 - 15	27	55	110		DNMO DNGO	1504○○	LLSDN43	LLP14	LLCL24	LLCS108	HKY30R
L -27055 - 15	27	55	110								
C5 -PDJN R -35060 - 15	35	60	110		DNMO DNGO	1504○○	LLSDN43	LLP14	LLCL24	LLCS108	HKY30R
L -35060 - 15	35	60	110								
C6 -PDJN R -45065 - 15	45	65	110		DNMO DNGO	1504○○	LLSDN43	LLP14	LLCL24	LLCS108	HKY30R
L -45065 - 15	45	65	110								

*Im Lieferumfang enthalten | included in delivery

PDUN

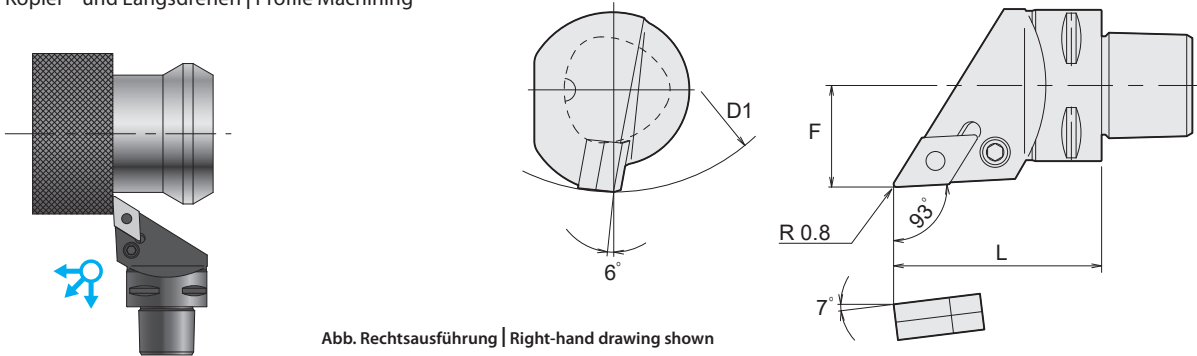
■ Zum Kopier- und Längsdrehen | For Edge · Profile Machining



Abb. Rechtsausführung | Right-hand drawing shown

Halter Holder	F	L	D1	Kg	Plattentyp Insert	Ersatzteile Accessory *				
						Unterlage Sheet	Spannschr. für Unterl. Sheet Stopper Pin	Hebel Clamp Lever	Spannschraube Clamp Screw	Schlüssel Wrench
C4 -PDUN R -27050 - 15	27	50	110		DNMO DNGO 1504	LLSDN43	LLP14	LLCL24	LLCS108	HKY30R
L -27050 - 15	27	50	110							
C5 -PDUN R -35060 - 15	35	60	110							
L -35060 - 15	35	60	110							
C6 -PDUN R -45065 - 15	45	65	110							
L -45065 - 15	45	65	110							

*Im Lieferumfang enthalten | included in delivery

PDHN

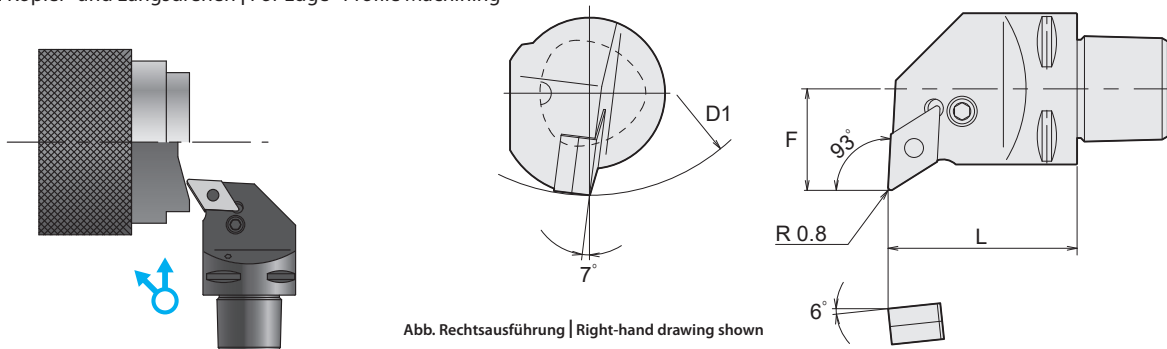
■ Zum Kopier- und Längsdrehen | For Exterior · Edge Profile Machining



Abb. Rechtsausführung | Right-hand drawing shown

Halter Holder	F	L	D1	Kg	Plattentyp Insert	Ersatzteile Accessory *				
						Unterlage Sheet	Spannschr. für Unterl. Sheet Stopper Pin	Hebel Clamp Lever	Spannschraube Clamp Screw	Schlüssel Wrench
C4 -PDHN R -27055 - 15	27	55	110		DNMO DNGO 1504	LLSDN43	LLP14	LLCL24	LLCS108	HKY30R
L -27055 - 15	27	55	110							
C5 -PDHN R -35060 - 15	35	60	110							
L -35060 - 15	35	60	110							
C6 -PDHN R -45065 - 15	45	65	110							
L -45065 - 15	45	65	110							

*Im Lieferumfang enthalten | included in delivery

PSSN

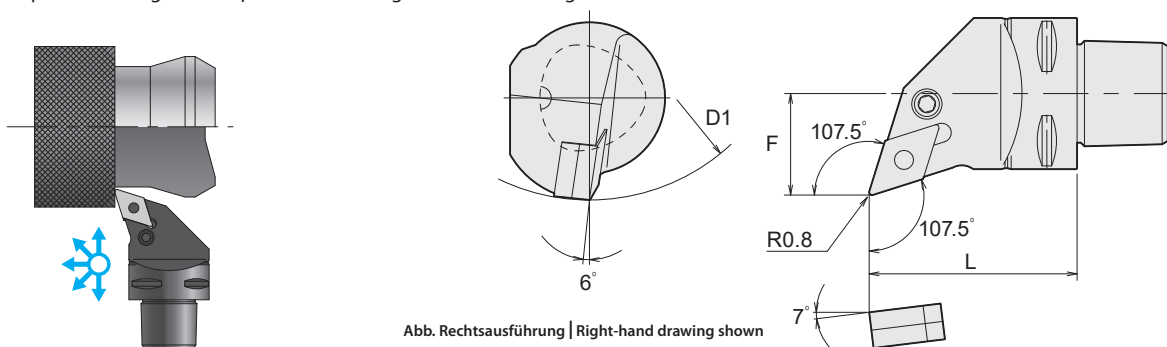
■ Zum Plan- und Längsdrehen | For Exterior · Profile Machining



Abb. Rechtsausführung | Right-hand drawing shown

Halter Holder	F	L	D1	Kg	Plattentyp Insert	Ersatzteile Accessory *					
						Unterlage Sheet	Spannschr. für Unterl. Sheet Stopper Pin	Hebel Clamp Lever	Spannschraube Clamp Screw	Schlüssel Wrench	
C3 -PSSN R -22045 - 12	22	45	90		SNMO SNGO	1204OO	LLSSN42	LLP14	LLCL14	LLCS108	HKY30R
L -22045 - 12	22	45	90								
C4 -PSSN R -27045 - 12	27	45	110								
L -27045 - 12	27	45	110								
C5 -PSSN R -35052 - 12	35	52	110								
L -35052 - 12	35	52	110								
C6 -PSSN R -45056 - 12	45	56	110								
L -45056 - 12	45	56	110								

*Im Lieferumfang enthalten | included in delivery

PSDN

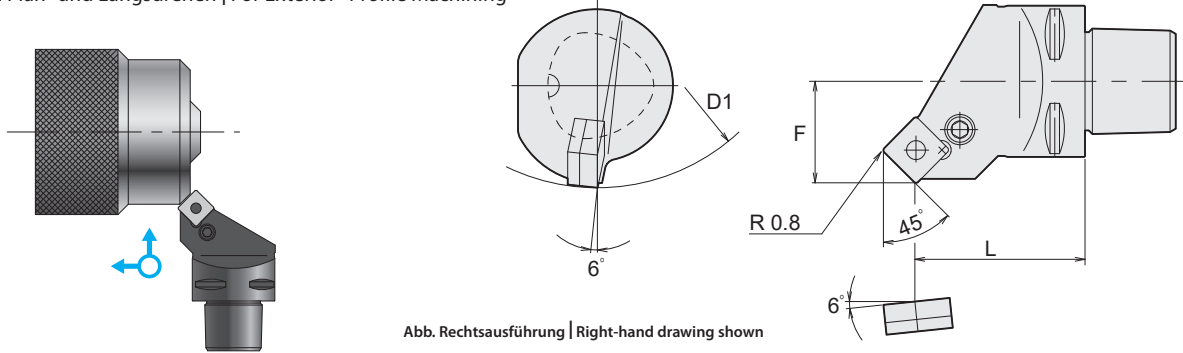
■ Zum Anfasen und Längsdrehen | For Chamfering · Exterior Profile Machining



Abb. Rechts- und Linksschneidend
For both Right and Left-hand.

Halter Holder	L	Kg	Plattentyp Insert	Ersatzteile Accessory *					
				Unterlage Sheet	Spannschr. für Unterl. Sheet Stopper Pin	Hebel Clamp Lever	Spannschraube Clamp Screw	Schlüssel Wrench	
C3 -PSDN N -00053 - 12	53		SNMO SNGO	1204OO	LLSSN42	LLP14	LLCL14	LLCS108	HKU30R
C4 -PSDN N -00055 - 12	55								
C5 -PSDN N -00060 - 12	60								
C6 -PSDN N -00065 - 12	65								

*Im Lieferumfang enthalten | included in delivery

PSKN

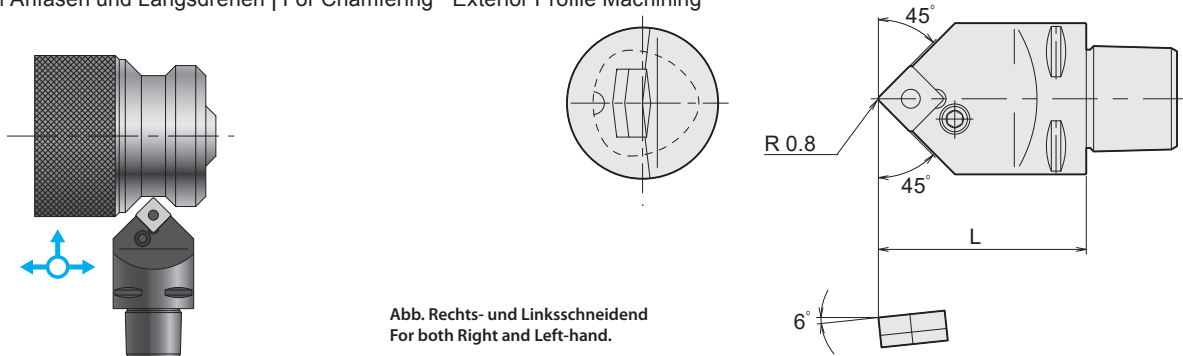
■ Zum Längsdrehen | For Edge Pull Machining



Abb. Rechtsausführung | Right-hand drawing shown

Halter Holder	F	L	D1	Kg	Plattentyp Insert	Ersatzteile Accessory *				
						Unterlage Sheet	Spannschr. für Unterl. Sheet Stopper Pin	Hebel Clamp Lever	Spannschraube Clamp Screw	Schlüssel Wrench
C4 -PSKN R -27050 - 12	27	50	110		SNMO SNGO 1204OO	LLSSN42	LLP14	LLCL14	LLCS108	HKY30R
L -27050 - 12	27	50	110							
C5 -PSKN R -35060 - 12	35	60	110							
L -35060 - 12	35	60	110							
C6 -PSKN R -45065 - 12	45	65	110							
L -45065 - 12	45	65	110							

*Im Lieferumfang enthalten | included in delivery

SVJB

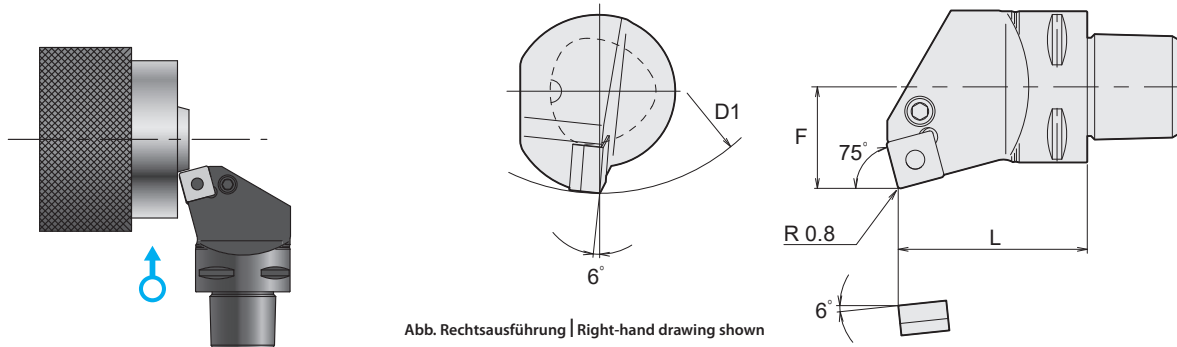
■ Zum allgemeinen Kopier-, Längs- und Plandrehen | For Profile Machining



Abb. Rechtsausführung | Right-hand drawing shown

Halter Holder	F	L	D1	R	Kg	Plattentyp Insert	Ersatzteile Accessory *		
							Spannschraube Clamp Screw	Schlüssel Wrench	
C3 -SVJB R -22045 - 11	22	45	70	0.4		VBM○ VBGO	1103○○	TS25	TKY08F
	L -22045 - 11	22	45	70	0.4				
C4 -SVJB R -27055 - 16	27	55	110	0.8		VBM○ VBGO	1604○○	TS43	TKY15F
	L -27055 - 16	27	55	110	0.8				
C5 -SVJB R -35060 - 16	35	60	110	0.8		VBM○ VBGO	1604○○	TS43	TKY15F
	L -35060 - 16	35	60	110	0.8				
C6 -SVJB R -45065 - 16	45	65	110	0.8		VBM○ VBGO	1604○○	TS43	TKY15F
	L -45065 - 16	45	65	110	0.8				

*Im Lieferumfang enthalten | included in delivery

SVQB

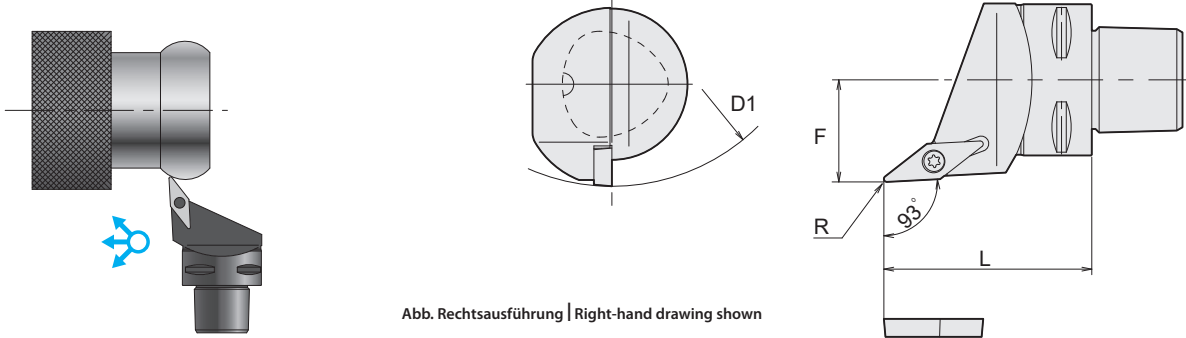
■ Zum Längs- und Kopierdrehen | For Edge Profile Machining



Abb. Rechtsausführung | Right-hand drawing shown

Halter Holder	F	L	D1	R	Kg	Plattentyp Insert	Ersatzteile Accessory *		
							Spannschraube Clamp Screw	Schlüssel Wrench	
C3 -SVQB R -22040 - 11	22	40	70	0.4		VBM○ VBGO	1103○○	TS25	TKY08F
	L -22040 - 11	22	40	70	0.4				
C4 -SVQB R -27050 - 16	27	50	110	0.8		VBM○ VBGO	1604○○	TS43	TKY15F
	L -27050 - 16	27	50	110	0.8				
C5 -SVQB R -35060 - 16	35	60	110	0.8		VBM○ VBGO	1604○○	TS43	TKY15F
	L -35060 - 16	35	60	110	0.8				
C6 -SVQB R -45065 - 16	45	65	110	0.8		VBM○ VBGO	1604○○	TS43	TKY15F
	L -45065 - 16	45	65	110	0.8				

*Im Lieferumfang enthalten | included in delivery

SVVB

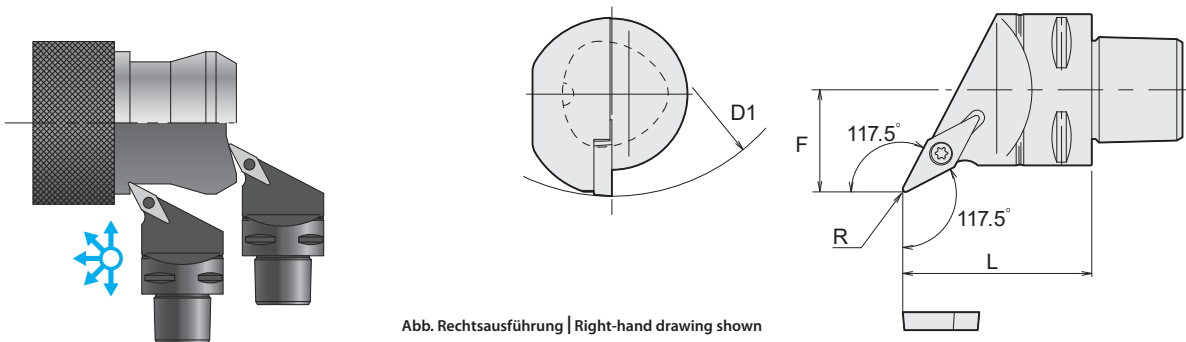
■ Zum Kopier-, Längs- und Plandrehen | For Profile Machining



Abb. Rechts- und Linksschneidend
For both Right and Left-hand.

Halter Holder	L	R	Kg	Plattentyp Insert	Ersatzteile Accessory *	
					Spannschraube Clamp Screw	Schlüssel Wrench
C3 -SVVB N -00045 - 11	45	0.4		VBMO VBGO	110300	TS25 TKY08F
C4 -SVVB N -00055 - 16	55	0.8		VBMO VBGO	160400	TS43 TKY15F
C5 -SVVB N -00060 - 16	60	0.8				
C6 -SVVB N -00065 - 16	65	0.8				

*Im Lieferumfang enthalten | included in delivery

DCLN

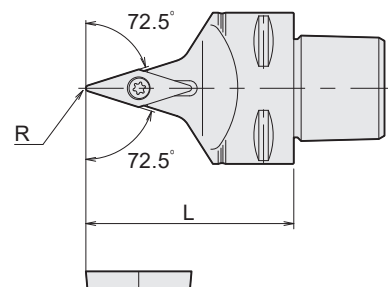
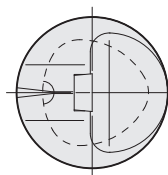
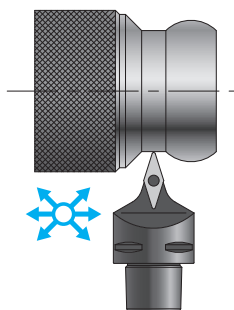
■ Zum Längs- und Plandrehen | Edge Machining



Abb. Rechtsausführung | Right-hand drawing shown

Halter Holder	F	L	L1	d	D1	RR	Kg	Plattentyp Insert	Ersatzteile Accessory *						
									Unterlage Sheet	Spannschr. für Unterl. Sheet Stopper Pin	Spannpratze Clamp Bridge	Druckfeder Spring	Spannschraube Clamp Screw	Schlüssel Wrench	
C4 -DCLN R -13080 - 09	13	80	56	20	32	16		CNMO	0903	LLSCN3T3	LLP23	DCK2211	DCS2	DC0520T	TKY15F
L -13080 - 09	13	80	56	20	32	16		CNGO							
C5 -DCLN R -17090 - 12	17	90	65	25	40	15		CNMO	1204	LLSCN42	LLP14	DCK2613	DCS1	DC0621T	TKY20F
L -17090 - 12	17	90	65	25	40	15		CNGO							
C6 -DCLN R -27140 - 12	27	140	113	40	50	10									
L -27140 - 12	27	140	113	40	50	10									

*Im Lieferumfang enthalten | included in delivery

DDUN

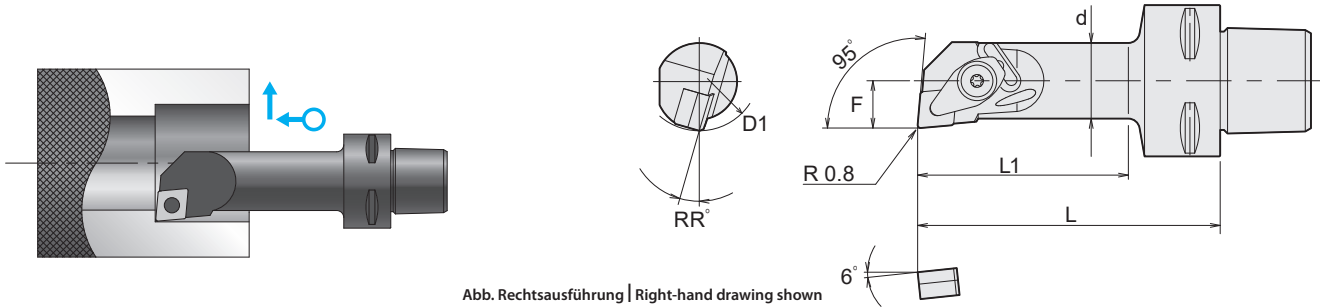
■ Zum Kopier- und Längsdrehen | For Profile Machining



Abb. Rechtsausführung | Right-hand drawing shown

Halter Holder	F	L	L1	d	D1	RR	Kg	Plattentyp Insert	Ersatzteile Accessory *						
									Unterlage Sheet	Spannschr. für Unterl. Sheet Stopper Pin	Spannpratze Clamp Bridge	Druckfeder Spring	Spannschraube Clamp Screw	Schlüssel Wrench	
C4 -DDUN R -17090 - 11	17	90	66	25	40	16		DNMO	1104	LLSDN32	LLP23	DCK2211	DCS2	DC0520T	TKY15F
L -17090 - 11	17	90	66	25	40	16		DNGO							
C5 -DDUN R -27140 - 15	27	140	117	40	50	12		DNMO	1504	LLSDN43	LLP24	DCK2613	DCS1	DC0621T	TKY20F
L -27140 - 15	27	140	117	40	50	12		DNGO							
C6 -DDUN R -27140 - 15	27	140	113	40	50	12									
L -27140 - 15	27	140	113	40	50	12									

*Im Lieferumfang enthalten | included in delivery

SVQB

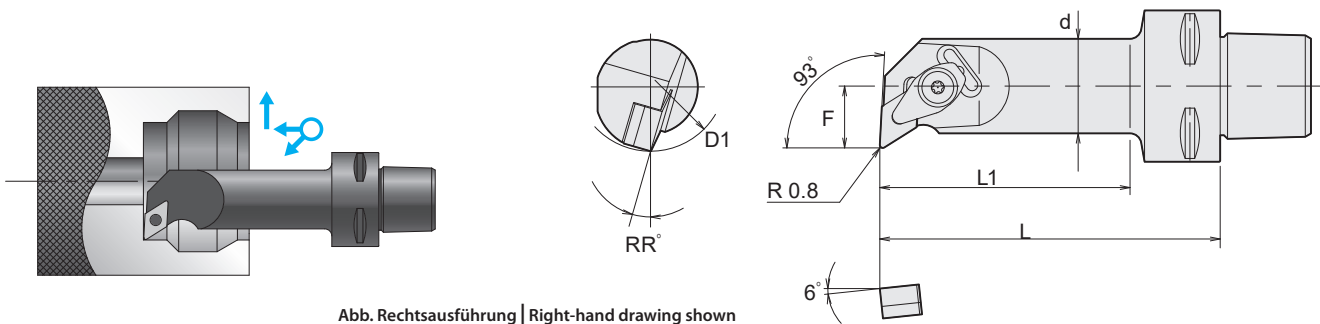
■ Zum Kopier- und Längsdrehen | For Undercut Machining



Abb. Rechtsausführung | Right-hand drawing shown

Halter Holder	F	L	L1	d	D1	RR	R	Kg	Plattentyp Insert	Ersatzteile Accessory *	
										Spannschraube Clamp Screw	Schlüssel Wrench
C3 -SVQB R -13070 - 11	13	70	49	16	22	8	0.4		VBM○ VBG○ 1103○○	TS25	TKY08F
L -13070 - 11	13	70	49	16	22	8	0.4				
C4 -SVQB R -13070 - 11	13	70	46	20	25	5	0.4		VBM○ VBG○ 1103○○	TS43	TKY15F
L -13070 - 11	13	70	46	20	25	5	0.4				
C5 -SVQB R -22110 - 16	22	110	86	32	40	7	0.8		VBM○ VBG○ 1604○○		
L -22110 - 16	22	110	86	32	40	7	0.8				
C6 -SVQB R -27145 - 16	27	145	118	40	50	5	0.8		VBM○ VBG○ 1604○○		
L -27145 - 16	27	145	118	40	50	5	0.8				

*Im Lieferumfang enthalten | included in delivery

SDZC

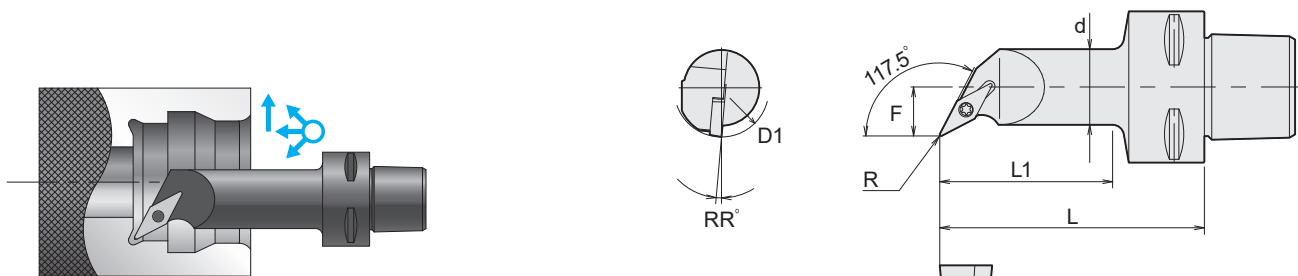
■ Zum rückwärts Innendrehen | For Back Boring Machining



Abb. Rechtsausführung | Right-hand drawing shown

Halter Holder	F	L	L1	L2	d	D1	RR	R	Kg	Plattentyp Insert	Ersatzteile Accessory *	
											Spannschraube Clamp Screw	Schlüssel Wrench
C3 -SDZC R -15080 - 11	15	80	59	96	20	27	5	0.8		DCMO DCGO 11T3○○	TS43	TKY15F
L -15080 - 11	15	80	59	96	20	27	5	0.8				
C4 -SDZC R -15080 - 11	15	80	56	96	20	27	5	0.8				
L -15080 - 11	15	80	56	96	20	27	5	0.8				
C5 -SDZC R -18090 - 11	18	90	65	106	25	32	8	0.8				
L -18090 - 11	18	90	65	106	25	32	8	0.8				

*Im Lieferumfang enthalten | included in delivery

STFC

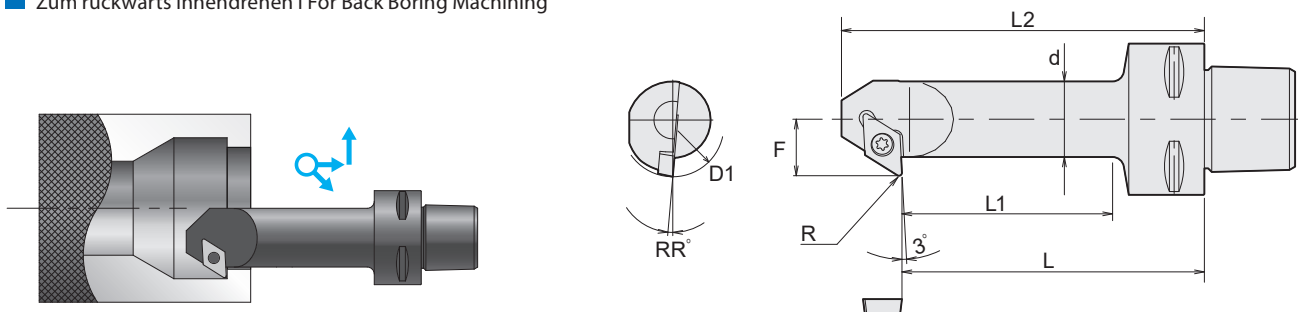
■ Zum Längsdrehen | For General Boring Machining



Abb. Rechtsausführung | Right-hand drawing shown

Halter Holder		F	L	L1	d	D1	RR	R	Kg	Plattentyp Insert	Ersatzteile Accessory *	
											Spannschraube Clamp Screw	Schlüssel Wrench
C3 -STFC	R -13075 - 16	13	75	54	20	25	7	0.8		TCM [○] TCG [○] 16T3 ^{○○}	TS43	TKY15F
	L -13075 - 16	13	75	54	20	25	7	0.8				
C4 -STFC	R -17090 - 16	17	90	66	25	32	6	0.8				
	L -17090 - 16	17	90	66	25	32	6	0.8				
C5 -STFC	R -22110 - 16	22	110	86	32	40	5	0.8				
	L -22110 - 16	22	110	86	32	40	5	0.8				

*Im Lieferumfang enthalten | included in delivery

HDC·A

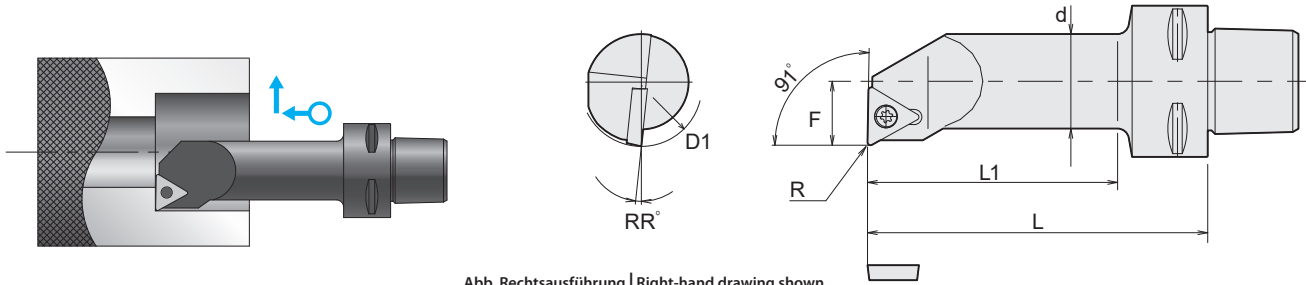
Hochgenauigkeits-Spannzangenfutter | High-Precision Collet Holder

■ Für präzise Bohr- und Fräsanwendungen | for high precision drilling, reaming and finish endmilling.

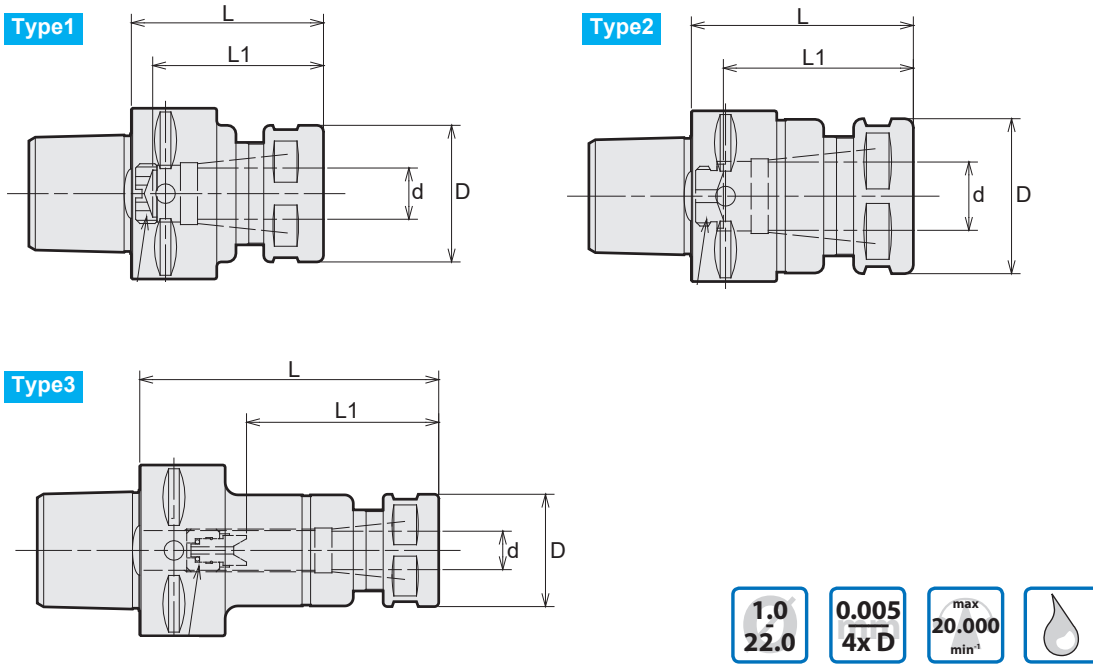

	Halter Holder		Typ Type	d	L	L1	D					
C3	-HDC07A	-35	1	0.5-7.0	35	24	23	FDC-07	S-0			
		-45	1	0.5-7.0	45	34	23					
	-HDC09A	-35	*2	1	2.5-9.0	35	29			26	FDC-09	S-1L
		-45		1	2.5-9.0	45	34			26		
	-HDC12A	-36	*2	2	2.5-12.0	36	31			32	FDC-12	S-3L
		-45	*2	2	2.5-12.0	45	37			32		
-HDC16A	-45	*2	2	3.5-16.0	45	37	36	FDC-16	S-4L			
C4	-HDC07A	-35	*1	1	0.5-7.0	35	24	23	FDC-07	S-0		
		-45		1	0.5-7.0	45	34	23				
		-52		3	0.5-7.0	52	22 ~ 29	23				
		-70		3	0.5-7.0	70	22 ~ 45	23				
	-HDC09A	-35	*1	1	2.5-9.0	35	24	26	FDC-09	S-1L		
		-45		1	2.5-9.0	45	34	26				
		-52		1	2.5-9.0	52	41	26				
		-70		3	2.5-9.0	70	27 ~ 45	26				
	-HDC12A	-35	*1*2	2	2.5-12.0	35	31	32	FDC-12	S-3L		
		-45	*2	1	2.5-12.0	45	38	32				
		-52		1	2.5-12.0	52	40	32				
		-70		3	2.5-12.0	70	33 ~ 45	32				
-HDC16A	-38	*1*2	2	3.5-16.0	38	36	36	FDC-16	S-4L			
	-52	*2	2	3.5-16.0	52	44	36					
-HDC22A	-54	*2	2	3.5-22.0	54	47	46	FDC-22	S-5L			



Halter Holder			Typ Type	d	L	L1	D		
C5	-HDC07A	-60	1	0.5-7.0	60	47	23	FDC-07	S-0
		-75	3	0.5-7.0	75	22 ~ 37	23		
		-105	3	0.5-7.0	105	22 ~ 45	23		
		-135	3	0.5-7.0	135	22 ~ 45	23		
	-HDC09A	-60	1	2.5-9.0	60	47	26	FDC-09	S-1L
		-75	3	2.5-9.0	75	27 ~ 37	26		
		-105	3	2.5-9.0	105	27 ~ 57	26		
		-135	3	2.5-9.0	135	27 ~ 57	26		
	-HDC12A	-60	1	2.5-12.0	60	43	32	FDC-12	S-3L
		-75	1	2.5-12.0	75	58	32		
		-105	3	2.5-12.0	105	33 ~ 69	32		
		-135	3	2.5-12.0	135	33 ~ 69	32		
-HDC16A	-60	1	3.5-16.0	60	38	36	FDC-16	S-4L	
	-75	1	3.5-16.0	75	53	36			
	-105	3	3.5-16.0	105	38 ~ 73	36			
	-135	3	3.5-16.0	135	38 ~ 82	36			
	-150	3	3.5-16.0	150	38 ~ 82	36			
-HDC22A	-75	2	3.5-22.0	75	57	46	FDC-22	S-5L	
	-105	3	3.5-22.0	105	47 ~ 68	46			
	-135	3	3.5-22.0	135	47 ~ 98	46			
	-150	3	3.5-22.0	150	47 ~ 103	46			
C6	-HDC07A	-60	1	0.5-7.0	60	45	23	FDC-07	S-0
		-75	3	0.5-7.0	75	22 ~ 37	23		
		-105	3	0.5-7.0	105	22 ~ 45	23		
		-135	3	0.5-7.0	135	22 ~ 45	23		
	-HDC09A	-60	1	2.5-9.0	60	45	26	FDC-09	S-1L
		-75	3	2.5-9.0	75	27 ~ 37	26		
		-105	3	2.5-9.0	105	27 ~ 57	26		
		-135	3	2.5-9.0	135	27 ~ 57	26		
	-HDC12A	-60	1	2.5-12.0	60	45	32	FDC-12	S-3L
		-75	1	2.5-12.0	75	60	32		
		-105	3	2.5-12.0	105	33 ~ 64	32		
	-HDC16A	-60	1	3.5-16.0	60	41	36	FDC-16	S-4L
-75		1	3.5-16.0	75	56	36			
-105		3	3.5-16.0	105	38 ~ 65	36			
-135		3	3.5-16.0	135	38 ~ 82	36			
-HDC22A	-75	2	3.5-22.0	75	56	46	FDC-22	S-5L	
	-105	3	3.5-22.0	105	47 ~ 68	46			
	-135	3	3.5-22.0	135	47 ~ 98	46			
	-150	3	3.5-22.0	150	47 ~ 103	46			

*1 - nicht für automatischen Wechsel geeignet | cannot be used with ATC

*2 - nur für Segmentspannung | only for segment clamping

Für weitere Informationen: NT TOOL Hauptkatalog
For more information, please refer to the NT TOOL CATALOG

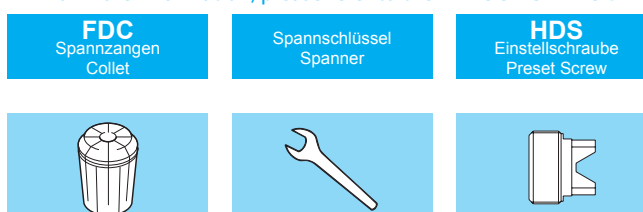

TSB

Bohrstangenhalter | Boring Bar Holder

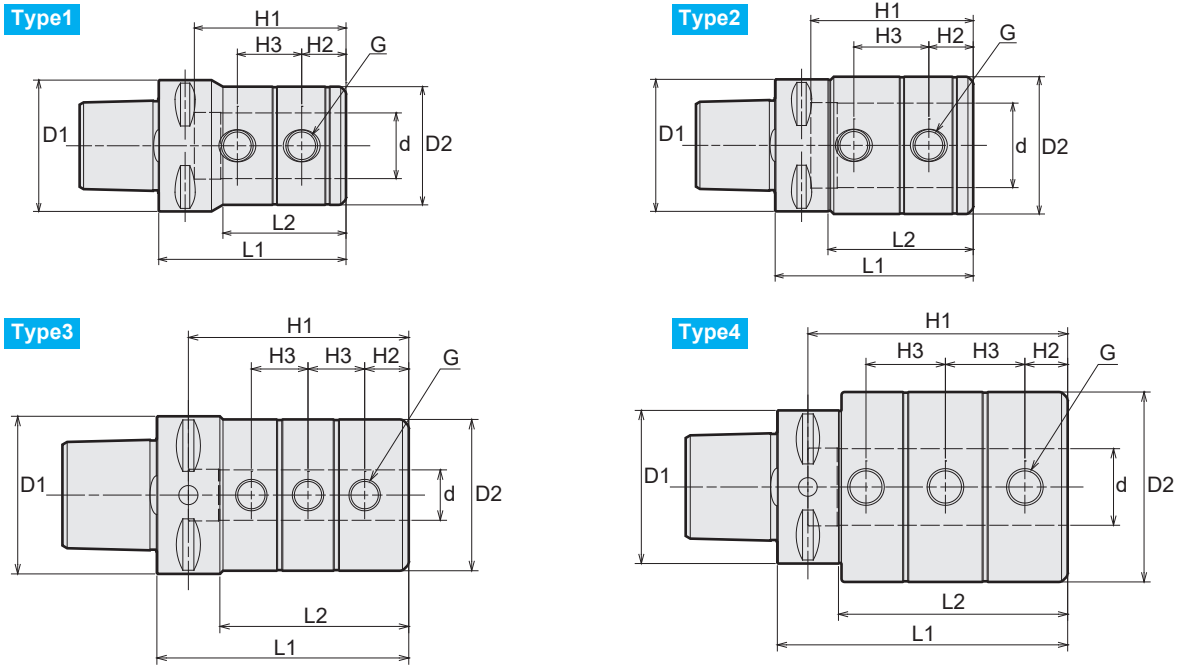

	Halter Holder	Typ Type	d	L1	(L2)	D1	D2	H1	H2	H3	G
C3	-TSB8 - 35	2	8	35	20	32	36	20	5	10	6
	-TSB10 - 35	2	10	35	20	32	36	20	5	10	6
	-TSB12 - 40	2	12	40	25	32	36	24	6	12	6
C4	-TSB8 - 40	1	8	40	18.8	40	36	20	5	10	6
	-TSB10 - 40	1	10	40	18.8	40	36	20	5	10	6
	-TSB12 - 45	1	12	45	23.8	40	36	24	6	12	6
	-TSB16 - 50	1	16	50	28.8	40	36	32	8	16	8
C5	-TSB8 - 60	1	8	60	40	50	28	40	9	20	8
	-TSB10 - 65	1	10	65	45	50	35	45	9	22	8
	-TSB12 - 70	1	12	70	50	50	42	50	9	22	8
	-TSB16 - 80	3	16	80	60	50	48	70	14	18	10
	-TSB20 - 80	4	20	80	60	50	52	70	14	18	10
	-TSB25 - 95	4	25	95	75	50	62	85	14	26	12
C6	-TSB8 - 65	11	8	65	43	63	28	40	9	20	8
	-TSB10 - 70	1	10	70	48	63	35	45	9	22	8
	-TSB12 - 75	1	12	75	53	63	42	50	9	22	8
	-TSB16 - 85	3	16	85	63	63	48	65	14	18	10
	-TSB20 - 85	3	20	85	63	63	52	70	14	18	10
	-TSB25 - 100	3	25	100	78	63	62	85	14	26	12
	-TSB32 - 115	3	32	115	93	63	62	100	14	30	12
	-TSB40 - 130	4	40	130	108	63	68	115	16	36	16

TSD

Werkzeughalter für WP-Bohrer | Side Lock Holder for Drills

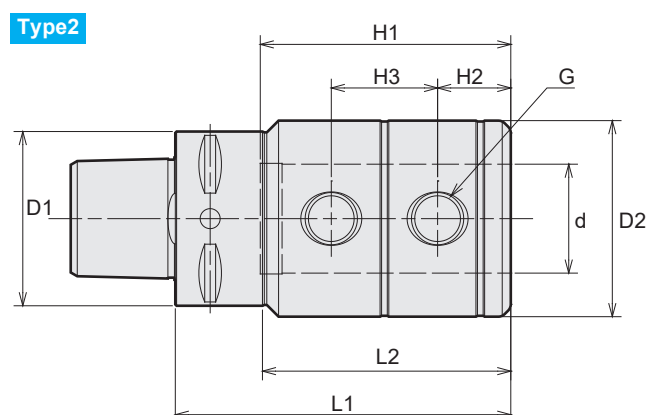
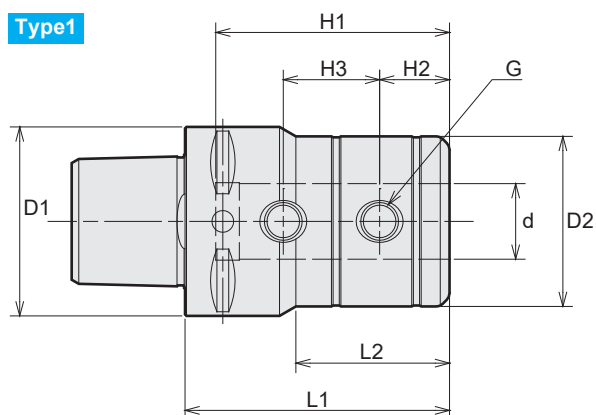

	Halter Holder	Typ Type	d	L1	(L2)	D1	D2	H1	H2	H3	G
C3	-TSD16 -56	2	16	56	41	32	36	49.5	14.8	20.4	8
	-TSD20 -60	2	20	60	45	32	40	51.5	14.8	22.4	8
C4	-TSD16 -56	1	16	56	32.5	40	36	49.5	14.8	20.4	8
	-TSD20 -60	1	20	60	60	40	40	51.5	14.8	22.4	8
	-TSD25 -77	2	25	77	57	40	45	57.5	16.8	24.4	12
C5	-TSD16 -60	1	16	60	40	50	36	49	14	18	10
	-TSD20 -60	1	20	60	40	50	40	51	14	18	10
	-TSD25 -70	1	25	70	50	50	45	57	14	26	12
	-TSD32 -75	2	32	75	55	50	52	61	14	30	12
C6	-TSD16 -70	1	16	70	48	63	36	49	14	18	10
	-TSD20 -70	1	20	70	48	63	40	51	14	18	10
	-TSD25 -70	1	25	70	48	63	45	57	14	26	12
	-TSD32 -75	1	32	75	53	63	52	61	14	30	12
	-TSD40 -85	2	40	85	63	63	65	71	16	36	16
	-TSD42 -85	2	42	85	63	63	67	71	16	36	16

CT·SA

Hochleistungs-Kraftspannfutter | High Performance Milling Chuck

■ Kraftvolle Zerspanung mit hoher Rundlaufgenauigkeit | Powerful milling with high run out accuracy

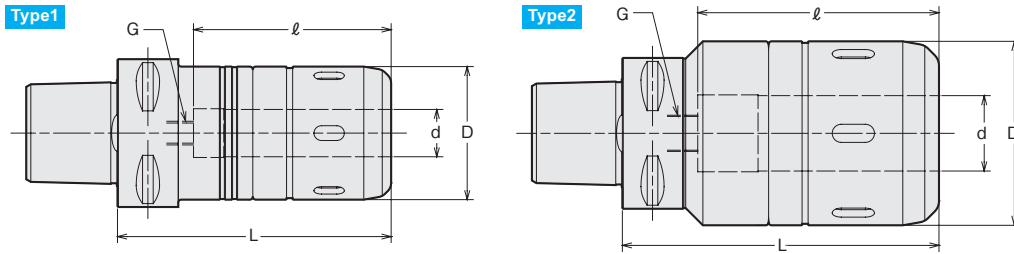

	Halter Holder			Typ Type	d	D	L	l	G		
C5	-CT16SA	- 70	*1,2	1	16	45	70	63	—	MC16-d	HS-1-16
		- 90		1	16	45	90	65	10		
	-CT20SA	- 75	*1,2	2	20	52	75	65	—	MC20-d	HS-2-20
		- 90	*1,2	2	20	52	90	80	—		
	-CT25SA	- 90	*1,2	2	25	61	90	80	—	MC25-d	HS-2.5-25
-105		*1	2	25	61	105	80	12			
C6	-CT16SA	- 70	*2	1	16	45	70	61	—	MC16-d	HS-1-16
		- 90		1	16	45	90	65	10		
		-105		1	16	45	105	65	10		
		-135		1	16	45	135	65	10		
	-CT20SA	- 75	*1,2	1	20	52	75	60	—	MC20-d	HS-2-20
		- 90	*1,2	1	20	52	90	75	—		
		-105	*1	1	20	52	105	80	12		
		-135		1	20	52	135	80	12		
	-CT25SA	- 80	*1,2	1	25	61	80	65	—	MC25-d	HS-2.5-25
		- 90	*1,2	1	25	61	90	75	—		
		-105	*1	1	25	61	105	80	12		
		-135		1	25	61	135	80	12		
	-CT32SA	- 90	*1,2	2	32	73	90	75	—	MC32-d	HS-3-32
		-105	*1,2	2	32	73	105	90	—		
		-135	*1	2	32	73	135	100	18		

*1: MC-A Spannhülsen nicht einsetzbar
*2: BL-Einstellschraube nicht einsetzbar

*1: MC-A Collets cannot be used
*2: BL-Back-up screw cannot be used

Für weitere Informationen: NT TOOL Hauptkatalog
For more information, please refer to the NT TOOL CATALOG

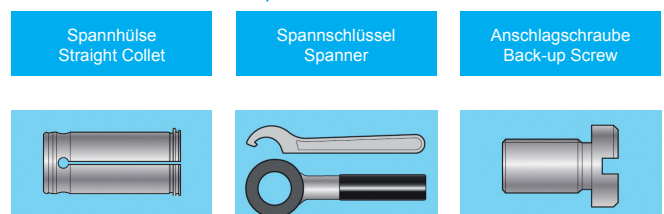



PHC · SA

Dehnspannfutter superschlank | Slim Hydro Chuck

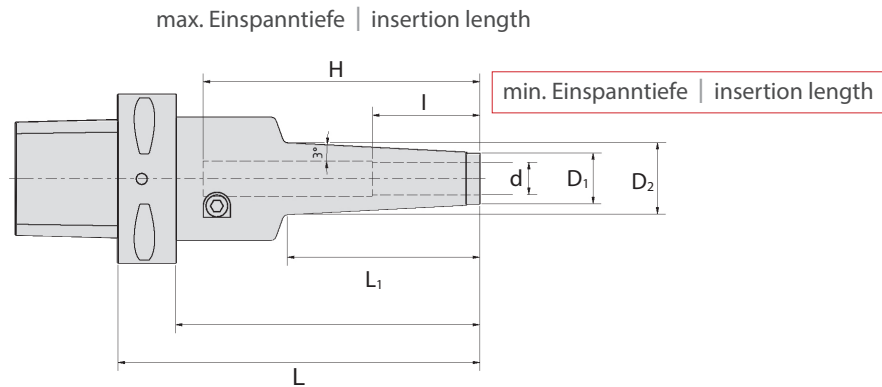
■ Superschlanke Bauform für schwer zugängliche Werkstückstellen | Super slim design for tight work piece areas



	Halter Holder	d	D ₁	D ₂	D ₃	L	L ₁	I	H		
C6	-PHC04SA -80	4	11	13	45,8	80	19	24	62	-	L-4T
	-PHC04SA -135	4	11	13	45,8	135	71	24	108	-	L-4T
	-PHC06SA -90	6	13	15,7	45,8	90	26	29	63	-	L-4T
	-PHC06SA -135	6	13	15,7	45,8	135	71	29	108	-	L-4T
	-PHC08SA -90	8	15	17,8	45,8	90	27	29	63	-	L-4T
	-PHC08SA -135	8	15	17,8	45,8	135	72	29	108	-	L-4T
	-PHC10SA -105	10	17	21,4	45,8	105	42	40	78	-	L-4T
	-PHC10SA -135	10	17	24,5	45,8	135	72	40	108	-	L-4T
	-PHC12SA -105	12	19	23,5	45,8	105	43	40	78	HS12-d	L-4T
	-PHC12SA -135	12	19	26,7	45,8	135	73	40	108	HS12-d	L-4T
	-PHC16SA -135	16	23	30,5	52,5	135	72	40	90	-	L-4T

Einstellschraube optional

Preset screw optional

Für weitere Informationen: NT TOOL Hauptkatalog
For more information, please refer to the NT TOOL CATALOG

Einstellschraube
Preset screw

Spannhülse
Collet

6kant-Schlüssel
Hex Wrench

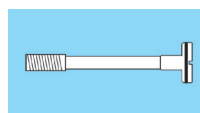

PHC · A

Power-Dehnspannfutter | Power Hydro Chuck

Hydro-Dehnspannfutter mit großer Spannflexibilität | Hydro chuck with collet holder flexibility.

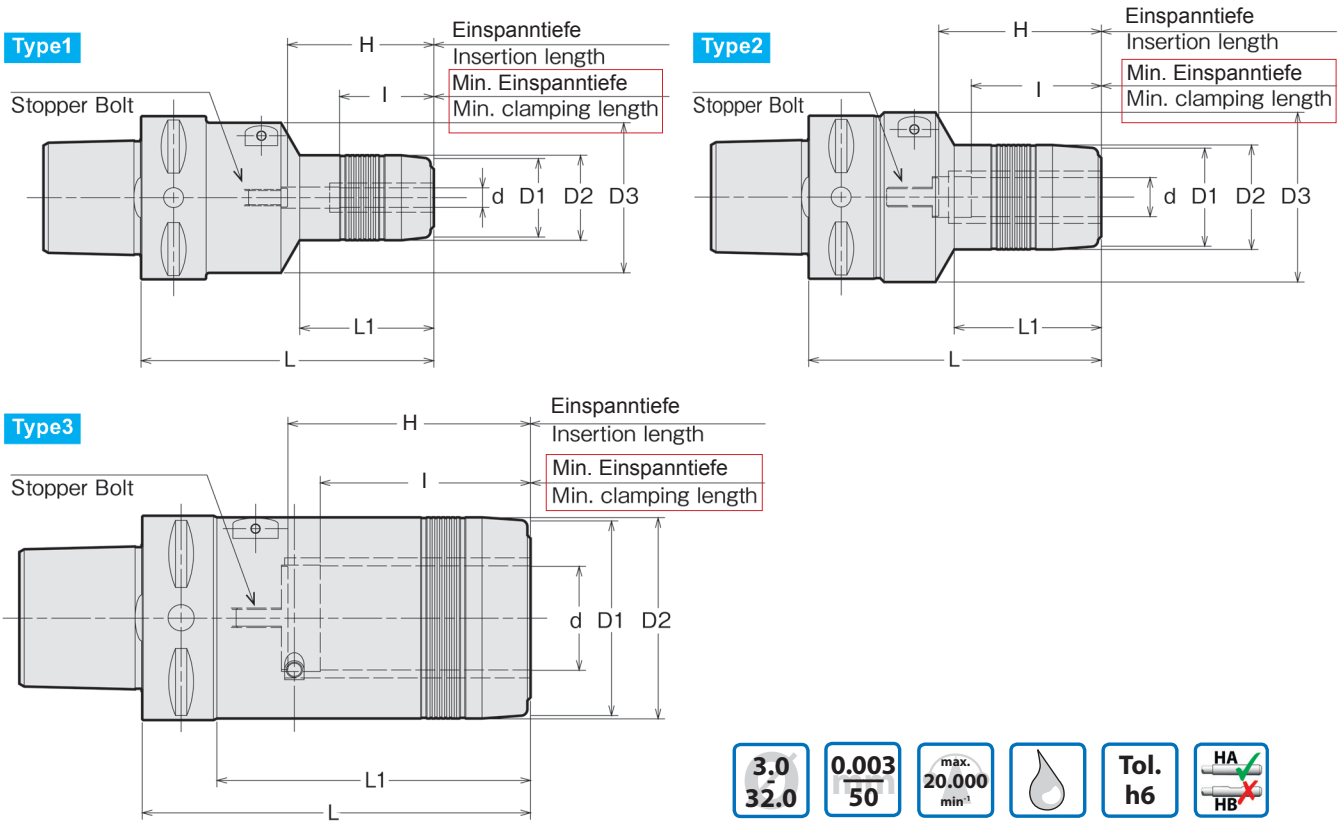





3.0 / 32.0
0.003 / 50
max. 20.000 min⁻¹
Oil
Tol. h6
HA HB

Halter Holder		Typ Type	d	L	L1	D1	D2	D3	H	I	Icons	
C5	-PHC03A -55	*1	1	3	55	4	—	24	46	42	18	L-4T
	-90	*1	1	3	90	44	—	25	46	49	18	
	-PHC04A -55	*1	1	4	55	9	—	25	46	42	24	
	-90	*1	1	4	90	45	—	25	46	49	24	
	-PHC06A -55		1	6	55	11	24	26	46	34	29	
	-90		1	6	90	41	24	26	46	45	29	
	-PHC07A -55		1	7	55	11	26	28	46	34	29	
	-90		1	7	90	41	26	28	46	45	29	
	-PHC08A -55		1	8	55	11	26	28	46	34	29	
	-90		1	8	90	41	26	28	46	45	29	
	-PHC09A -60	*1	1	9	60	19	28	30	46	47	33	
	-90		1	9	90	44	28	30	46	50	40	
	-PHC10A -60	*1	1	10	60	19	28	30	46	47	33	
	-90		2	10	90	44	28	30	52	50	40	
	-PHC11A -60	*1	1	11	60	17	30	32	46	47	33	
	-90		2	11	90	45	30	32	52	50	40	
	-PHC12A -60	*1	1	12	60	17	30	32	46	47	33	
	-90		2	12	90	45	30	32	52	50	40	
	-PHC13A -75		1	13	75	17	34	36	46	50	33	
	-90		2	13	90	46	34	36	52	50	40	
	-PHC14A -75		1	14	75	17	34	36	46	50	33	
	-90		2	14	90	46	34	36	52	50	40	
	-PHC15A -75		1	15	75	18	36	38	46	50	33	
	-90		2	15	90	46	36	38	52	50	40	
	-PHC16A -75		1	16	75	18	36	38	46	50	33	
	-90		2	16	90	46	36	38	52	50	40	
	-PHC20A -90		1	20	90	49	40	42	46	50	40	
	-125		1	20	125	69	40	42	46	70	40	
	-PHC25A -105		2	25	105	59	50	52	62	60	50	

* ohne Einstellschraube

* without preset screw



Halter Holder		Typ Type	d	L	L1	D1	D2	D3	H	I				
C6	-PHC03A	-50	※1	1	3	50	4	—	24	46	35	18		
		-90	※1	1	3	90	44	—	25	46	49	18		
	-PHC04A	-55	※1	1	4	55	9	—	25	46	40	24		
		-90	※1	1	4	90	45	—	25	46	49	24		
	-PHC06A	-60		1	6	60	11	24	26	46	34	29		
		-90		1	6	90	41	24	26	46	45	29		
		-120		1	6	120	41	24	26	46	45	29		
	-PHC07A	-60		1	7	60	11	26	28	46	34	29		
		-90		1	7	90	41	26	28	46	45	29		
	-PHC08A	-60		1	8	60	11	26	28	46	34	29		
		-90		1	8	90	41	26	28	46	45	29		
		-120		1	8	120	41	26	28	46	45	29		
	-PHC09A	-65	※1	1	9	65	19	28	30	46	47	33		
		-90		1	9	90	44	28	30	46	50	40		
	-PHC10A	-65	※1	1	10	65	19	28	30	46	47	33		
		-90		1	10	90	44	28	30	52	50	40		
		-120		1	10	120	64	28	30	52	70	40		
	-PHC11A	-65	※1	1	11	65	17	30	32	46	47	33		
		-90		1	11	90	45	30	32	52	50	40		
	-PHC12A	-65	※1	1	12	65	17	30	32	46	47	33		
		-90		1	12	90	45	30	32	52	50	40		
		-120		1	12	120	65	30	32	52	70	40		
	-PHC13A	-75		1	13	75	17	34	36	46	45	33		
		-90		1	13	90	46	34	36	52	50	40		
	-PHC14A	-75		1	14	75	17	34	36	46	45	33		
		-90		1	14	90	46	34	36	52	50	40		
		-120		1	14	120	66	34	36	52	70	40		
	-PHC15A	-75		1	15	75	18	36	38	46	45	33		
		-90		1	15	90	46	36	38	52	50	40		
	-PHC16A	-75		1	16	75	18	36	38	46	45	33		
		-90		1	16	90	46	36	38	52	50	40		
		-120		1	16	120	66	36	38	52	70	40		
	-PHC20A	-90		1	20	90	49	40	42	46	50	40		
	-120		1	20	120	69	40	42	46	70	40			
-PHC25A	-105		1	25	105	59	50	52	62	60	50			
	-120		1	25	120	59	50	52	62	80	50			
-PHC32A	-120		3	32	120	96	60	62	-	75	65			

※ ohne Einstellschraube

※ without preset screw

Für weitere Informationen: NT TOOL Hauptkatalog
For more information, please refer to the NT TOOL CATALOG

Spannhülse
Collet

6kant-Schlüssel
Hex Wrench

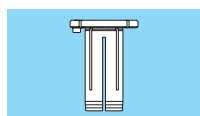

SRD

DIN-Schrumpffutter | Shrink Fit (DIN Standard)

■ Schrumpffutter für allgemeine Bearbeitung | Shrink Fit Chuck for general machining

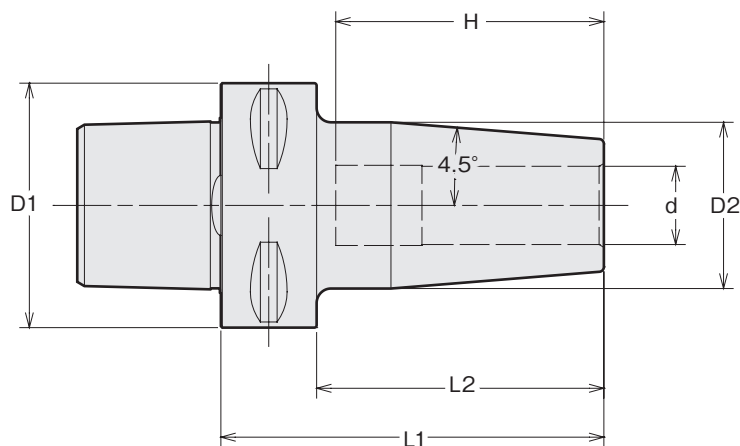

6.0
-
32.0

0.003
mm

max.
20.000
min⁻¹



Tol.
h6



	Halter Holder		d	D1	D2	L1	L2	H
C5	-SRD6A	- 75	6	50	27	75	55	36
	-SRD8A	- 75	8	50	27	75	55	50
	-SRD10A	- 75	10	50	31	75	55	50
	-SRD12A	- 75	12	50	31	75	55	50
	-SRD14A	- 80	14	50	34	80	60	55
	-SRD16A	- 80	16	50	34	80	60	55
	-SRD18A	- 80	18	50	41	80	60	55
	-SRD20A	- 85	20	50	42	85	65	55
C6	-SRD6A	- 80	6	63	27	80	58	36
	-SRD8A	- 80	8	63	27	80	58	50
	-SRD10A	- 80	10	63	31	80	58	50
	-SRD12A	- 80	12	63	32	80	58	50
	-SRD14A	- 85	14	63	34	85	63	55
	-SRD16A	- 85	16	63	34	85	63	55
	-SRD18A	- 85	18	63	42	85	63	55
	-SRD20A	- 85	20	63	42	85	63	55
	-SRD25A	- 90	25	63	53	90	68	62
	-SRD32A	- 95	32	63	53	95	73	62

Schafttoleranz h6 | nur VHM-Schäfte

Shank tolerance h6 | only carbide tools

FMH • A *cool series*

Aufsteck-Fräsdorn mit Kühlkanalbohrungen | Face Mill Arbor with coolant channels

■ Aufsteck-Fräsdorn mit Kühlkanalbohrungen | Face Mill Arbor with coolant channels

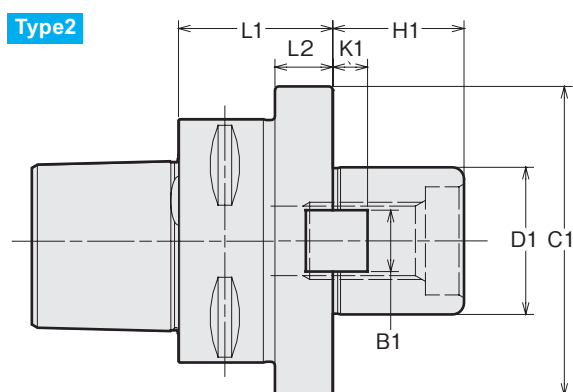
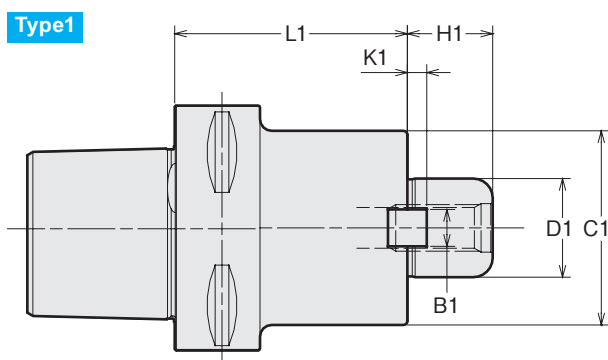

Halter Holder	Type	D1	L1	L2	C1	H1	B1	K1			Anzugsschraube Clamp bolt	Messerkopf Cutter dia.
C6 -FMH16A-34 - 60	1	16	60	22	34	17	8	5			MBA-M8	80
C6 -FMH16A-34 - 90	1	16	90	22	34	17	8	5			MBA-M8	80
C6 -FMH22A-47 - 60	2	22	60	22	47	18	10	5			MBAM10	100
C6 -FMH22A-47 - 90	2	22	90	22	47	18	10	5			MBAM10	100
C6 -FMH27A-60 - 60	2	27	60	22	60	20	12	6			MBA-M12	80
C6 -FMH27A-60 - 90	2	27	90	22	60	20	12	6			MBA-M12	80
C6 -FMH32A-96 - 60	2	32	60	22	96	22	14	7			MBA-M16	100
C6 -FMH32A-96 - 90	2	32	90	22	96	22	14	7			MBA-M16	100

Anzugsschraube im Lieferumfang enthalten | Clamp bolt is included

MS

Grundaufnahme | Master Shank

■ Grundaufnahme für Multibore System | Master shank for multibore tooling system

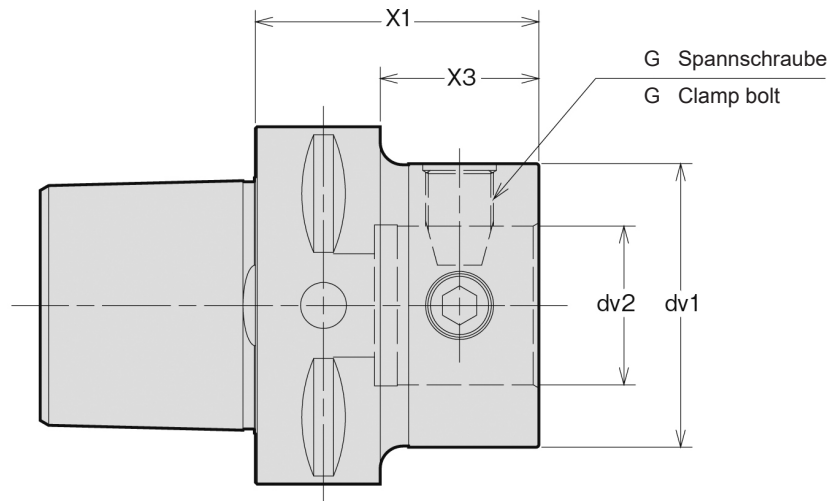



	Halter Holder		X1	X3	dv1	dv2	G
C5	-1811	-65	65	15	18	11	C5-1
	-2211	-65	65	15	22	11	C5-2
	-2514	-64	64	19	25	14	C8-1
	-3218	-44	44	24	32	18	C8-2
	-4022	-45	45	25	40	22	C10-1
	-5028	-50	50	(30)	50	28	C12-1
	-6336	-70	70	(50)	63	36	C16-1
C6	-1811	-70	70	18	18	11	C5-1
	-2211	-70	70	18	22	11	C5-2
	-2514	-69	69	22	25	14	C8-1
	-3218	-44	44	22	32	18	C8-2
	-4022	-45	45	23	40	22	C10-1
	-5028	-50	50	28	50	28	C12-1
	-6336	-55	55	(33)	63	36	C16-1
	-8036	-60	60	(38)	80	36	C16-2

SFH · S

SynchroFit-Gewindeschneidfutter | SynchroFit Tap Holder

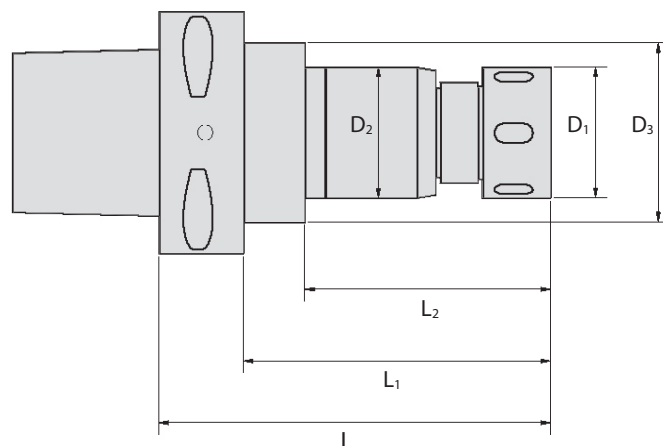
■ mit einzigartigem Schnittdruckausgleich | with unique cutting force compensation



Halter Holder		D ₁	D ₂	D ₃	L	L ₁	L ₂		
C5	-SFH12S -105	32	34	46,5	105	85	63	ER16-GB	FK-0034
	-SFH18S -120	42	40	46,5	120	100	78	ER25-GB	HS-1-16
C6	-SFH12S -105	32	34	46,5	105	83	63	ER16-GB	FK-0034
	-SFH18S -120	42	40	46,5	120	98	78	ER25-GB	HS-1-16

Für weitere Informationen: NT TOOL Hauptkatalog
For more information, please refer to the NT TOOL CATALOG

ER-GB
Spannzangen
Collet

Spannschlüssel
Spanner



Spannkompetenz aus einer Hand

Clamping expertise from a single source



Hochleistungs-Kraftspannfutter
High Performance Milling Chucks



Power-Dehnspannfutter Serie
Power Hydro Chuck Series



Dehnspannfutter superschlank
Slim Hydro Chucks



Hochgenauigkeits-Spannzangenfutter
High Precision Collet Chucks



Spannsysteme mit Rundlauf "0"
R-ZERO Tooling



Schrumpfspannfutter
Shrink Fit Chucks



SynchroFit-Gewindeschneidfutter
SynchroFit Tapping Holder



Präzisions-Schnellaufspindel
Precision Hyper Spindle

NT TOOL EUROPE GmbH

Siemensstrasse 17 A
61449 Steinbach
Germany

+49-(0)6171-91639 - 0

+49-(0)6171-91639-90

info@nttooleurope.com

www.nttooleurope.com