

yamasa

Brighten your future...

ROLLER BURNISHING | SKIVE BURNISHING | DEEP ROLLING
TOOLS AND MACHINES

Copyright © 2017



YAMASA LTD.

Metal isleri 3. cad. nr.157
35476 kısıkköy - izmir / TR
Phone : +90 232 257 53 35
Fax : +90 232 257 53 36
E-mail : info@yamasa.com.tr
www.yamasa.com.tr



yamasa

Brighten your future...

Since 1958

Our company has been operating since 1958. YAMASA is specialized in producing of Roller Burnishing, Skive-Burnishing and Deep Rolling Tools.

Our enterprise was carried on its growth within years. With the continuously developed technology and specialized staff, it increased the variety of the products and grew dynamically day by day. It has been one of the biggest enterprise as producer in this sector. YAMASA offers ideal solutions to the worldwide customers.

Our products are used in such as precise tube production, hydraulic-pneumatic, automotive industry, aircraft industry, all kind of machine production, agricultural vehicles, ship building industry, railway industry, light motorized vehicles, heavy duty machines, heating and cooling industry, information technologies industry, electronic household industry and defence industry. We meet the current requirements of our customers in these all sectors with our service and product quality and applied stable price policy.

The properties which make YAMASA an ideal solution partner

- Qualified and fast production of standard and special tools
- Qualified, fast technical service and support
- A wide variety of products
- Economic prices
- High stock capacity
- Delivery on time



Our Mission

- To answer the needs and surpass all expectations of the customers with a higher quality
- To invest continuously in expertness and technology
- To know the worth of natural sources, to care the environment and ensure our future

Our Vision

- The unconditional satisfaction of our customers
- To prove the trustworthiness to the persons or companies we work with and to be preferred everytime



Roller burnishing technology		2-3
Deep rolling technology		4-5
Skive-burnishing technology		6-7
DX Series	Internal roller burnishing tools - Multi roller <i>For cylindrical holes</i>	8-17
	DX type between Ø005-014	10
	DX type between Ø015-021	11
	DX type between Ø022-031	12
	DX type between Ø032-034	13
	DX type between Ø035-049	14
	DX type between Ø050-080	15
	DX type between Ø081-160	16
	DX type between Ø161-350	17
MX Series	External roller burnishing tools - Multi roller <i>For cylindrical shafts</i>	18-25
	MX type between Ø001-014	20
	MX type between Ø015-024	21
	MX type between Ø025-049	22
	MX type between Ø050-085	23
	MX type between Ø086-110	24
	MX type between Ø111-160	25
MDX Series	Internal micro roller burnishing tools - Multi roller <i>For cylindrical holes</i>	26
MXS Series	External micro roller burnishing tools - Multi roller <i>For cylindrical shafts</i>	27
K Series	Taper-flat surface burnishing tools - Multi roller <i>For male-female tapers and flat surfaces</i>	28-29
SX Series	Single roller burnishing tools	30-35
	SX-5, SX-8 types <i>For cylindrical external surface, flat surfaces, tapers and holes</i>	30-31
	SX-14 type <i>For cylindrical external surface, flat surfaces, tapers and holes</i>	32-33
	SX-35M, SX-35D, SX-52D types <i>For limited length of holes, shafts and internal-external tapers</i>	34-35
RX Series	Single roller burnishing tools RX-45, RX-45H types <i>For fillets, radii, contours, and spherical surfaces</i>	36-37
RXS Series	Single roller burnishing tools RXS-45, RXS-90, RXS-90P types <i>For spherical surfaces, contours, radii and groove flanks</i>	38-39
CEOS Series	Combined skive-burnishing tools <i>For hydraulic cylinders, tubes</i>	40-49
	CEOS type between Ø038-049	42
	CEOS type between Ø050-064	43
	CEOS type between Ø065-079	44
	CEOS type between Ø080-099	45
	CEOS type between Ø100-139	46
	CEOS type between Ø140-179	47
	CEOS type between Ø180-209	48
	CEOS type between Ø210-300	49
CX Series	Skive and roller burnishing tools CX-R, CX-CS, CX-D types <i>For hydraulic cylinders, tubes</i>	50
UX Series	Multiple head roller burnishing tools <i>For stepped and axial holes</i>	51
MXM Series	Roller burnishing machines DVH, DPH, NC types <i>For cylindrical shafts</i>	52



YAMASA Roller Burnishing is a method to make the workpiece, which has passed through the pre-machining, smooth and hard. It is possible to process any kind of metallic material by using this method. The roller burnishing is done by contacting of the rollers on the surface of the workpiece by the help of a precision mechanism. When such a contact is obtained, the workpiece or the tool turns at a specified speed, then the rollers go forward on the workpiece's surface by rotation. In addition, a pressure is applied on the surface of the workpiece with a certain force thus the process of roller burnishing is achieved. The effects that occur at the point where a single roller is contact to the surface of the workpiece are as follows;

The contact of the roller to the workpiece is obtained by pressure. At this point, while the protrusions on the surface are being pressed, the gaps in bottom are filled up simultaneously. This process that we call as plastic deformation is repeated as long as the rotation, pressing and feeding continues (fig.1). Therefore the smooth and bright surfaces are obtained.

The feeding speed of roller and the pressure applied on the workpiece is defined according to the surface roughness which is required to obtain. The roughness values decrease by slowing down the feeding speed and increasing the pressure. On the contrary, while the pressure decreases and the speed of feeding becomes faster, the surface roughness values will increase.

After the roller burnishing process, dimensional changes occur on the surface. Such a change is equal to the roughness value of the surface. So it is possible to say that such a change occurs in the shape and dimension of the workpiece remains inside the roughness limits.

It is possible to burnishing all kind of metallic materials up to 42-45 HRC with roller burnishing technology.

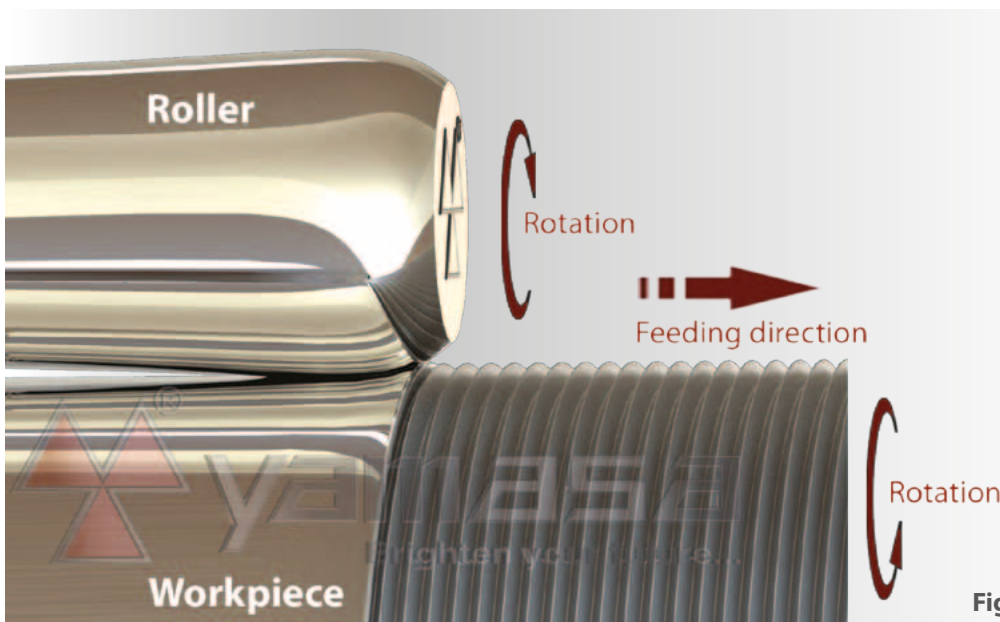

Figure 1 - Roller burnishing process

Pre-machining for roller burnishing process

Surface of the workpiece must be made suitable for roller burnishing. For this, pre-machining is advised. Pre-machining is necessary for getting standard and good surface quality after roller burnishing. As pre-machining lathe, reaming, grinding or etc. processes can be applied.

On the workpiece, stock allowance is left for roller burnishing. Pre-machining is applied by considering this stock allowance. Roller burnishing doesn't pull off a piece from surface, only accumulates roughnesses of the surface on to each other, in this context we can say that generally roughness depth determines the stock allowance. Stock allowance equals to roughness depth (Rz). Thus, on the workpiece, stock allowance is left as roughness depth.

After pre-machining roughness depth must be between $Rz = 5 - 30 \mu\text{m}$ (max. $50 \mu\text{m}$) according to diameter and material type.

Before roller burnishing to obtain the most appropriate surface, you can use the lathing formula below;

Feed rate per revolution (mm/rev.) = $0.5 \times$ cutter edge radius (mm)

The workpiece after pre-machining becomes ready for roller burnishing process. After the roller burnishing process, there is no roughness left on the surface (see figure).

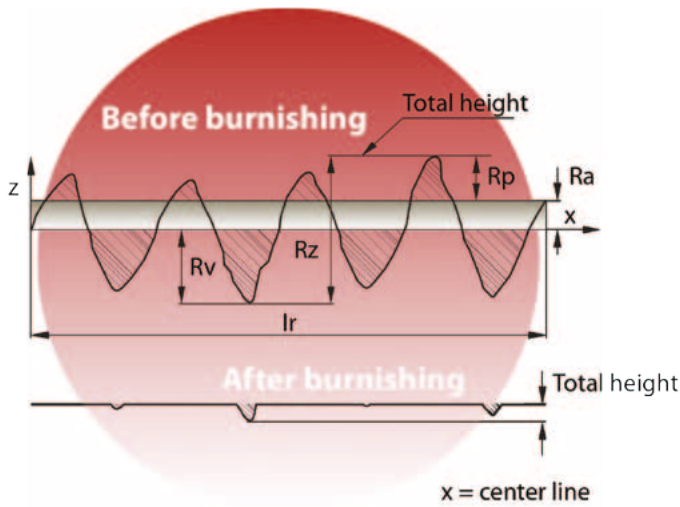

Figure 2 - Surface profiles after pre-machining and roller burnishing

Sample application;

Workpiece		Roller burnishing parameters	
Diameter	Ø40,00 mm	Revolution	800 rev./min.
Rolling lenght	60 mm	Feeding	0,9 mm/rev.
Material	Steel	Process time	5 sec.
Pre-machining	Lathe		



Figure 3 - Before and after roller burnishing surfaces

Available surfaces

Cylindrical holes, cylindrical external surfaces, internal and external tapers, fillets / radiuses, grooves, spherical and flat surfaces.

Advantages of roller burnishing

- The surfaces in quality of $Rz < 1 \mu\text{m}$ / $Ra < 0,16 \mu\text{m}$ can be obtained.
- It is possible to catch the desired size tolerance easily and rapidly.
- The surface harden in the same time. It ensures the processed surface to become stronger, more brilliant and slippery.
- It is too much economical, low spare part consumption, it saves time, money and energy.
- The process is completed by one pass. The process time is very short.
- No sawdust and residues occur. No noise and damage to the environment.
- Low lubrication and coolant.

Surface roughness

Before burnishing

After burnishing

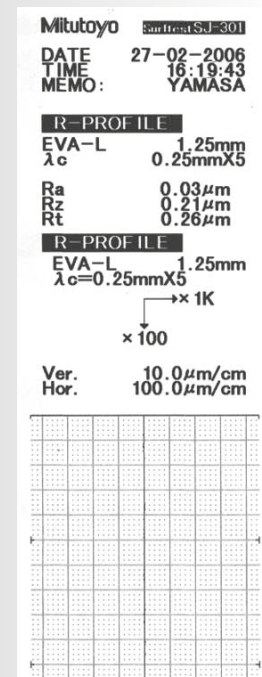
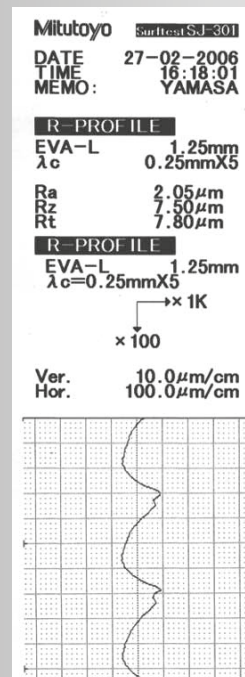

Figure 4 - Surface profiles



Figure 5 - Compression stress after deep rolling

This method increases fatigue strength of parts which are exposed to dynamic stress under high pressure or load and prevents or decreases cracks and fractures which may be derived from stress and depreciation.

The object resistance decreases due to the instantaneous changes in cross-section and cornered structure on the parts carrying loads or being exposed to loads (machine elements, shaft, axles etc.). To prevent this, round lines such as Radius are used. To a great extent, critical cross-section is usually found in these areas where notch effect exists. Materials are usually cracked or broken from these areas. The aim of deep rolling method is to decrease notch effect and prevent cracks and fractures by increasing the fatigue strength.

Deep rolling is the most suitable and fastest method of mechanical metal processing. The success of this method is ensured as a result of three distinct physical effects occurring at the same time.

1. With compression stress remained on the surface after deep rolling. This stress never decreases following deep rolling.
2. By increasing the resistance of the material.
3. By polishing the surface (by smoothing micro burrs that operations such as grinding etc. could not eliminate).

To become successful in the operation of deep rolling, it is necessary to use right parameters of operation. In this sense, the settings of rotation, feeding and rolling force are important.

During the operation of deep rolling, deep rolling roller is pressed onto the workpiece which it has contacts with. This operation plasticizes upper layer and changes micro structure of the surface. Deep rolling force which occurs on its contact point with the surface generates Hertzian contact force in the fringe area of the material. If this force is greater than tensile strength of material, the material begins to exude from the sideward of the surface. Compression strength which remains after operation stays in this area by increasing the fatigue strength.

If plastic deformation takes place under the level of room temperature or recrystallization, this is named as "cold working." The amount of produced cold-working depends on the rolling force, feeding speed, form of deep rolling roller and workpiece and properties of the material. Rolling force and feeding speed are the variable parameters. For instance, low rolling force causes low level cold-working.

Characteristic acquisitions are obtained depending on the amount of cold working and the properties of the material. Depth of compression stress which is constituted after deep rolling operation is subject to change.

For instance, when low rolling force or small deep rolling rollers are used, low values come up. Similarly, when high rolling force or big deep rolling rollers are used, immersion depth and compression stress depth increase.

Rolling force

Rolling force deeply affects the amount of cold working and compression stress emerged on the surface of workpiece at the end of deep rolling. For this reason, implementing appropriate parameters of rolling force and controlling them increase the reliability of the operation.

Advantages of deep rolling

- It decreases notch effect of dynamically operating workpieces; through increasing fatigue strength, it is the most effective way to prevent cracks and fractures.
 - The constant durability of workpieces having been processed in deep rolling increases at a rate of 400%.
 - During cold-working process, deep rolling is the single metal processing method that achieves high surface quality by polishing the surface of workpiece and provides remnant compression stress at the same time.
 - Cold-working realized with deep rolling increases surface hardness and eliminate all micro notches and burrs through polishing, makes the corrosion difficult.
- During processes other than deep rolling, micro notches and burrs remained on the workpieces may always cause tensile and depreciation fractures. In addition, the processes such as throwing ball cause notch on the surface and increases surface roughness. For this reason, the surface needs to be grinded during the second operation. Deep rolling removes the need of other time-consuming processes such as grinding which is used for elimination of notches and burrs.

- Deep rolling can be realized at a single calibration just after turning operation.
- Deep rolling is the most advanced and economical way among other systems to increase fatigue strengths and polish surfaces.
- It is the most reliable processing method among the others known so far.
- It is very useful with its miniature tools which are suitable for all machines.
- It provides savings from the material used in workpiece and its weight.
- It provides saving from heat treatment.

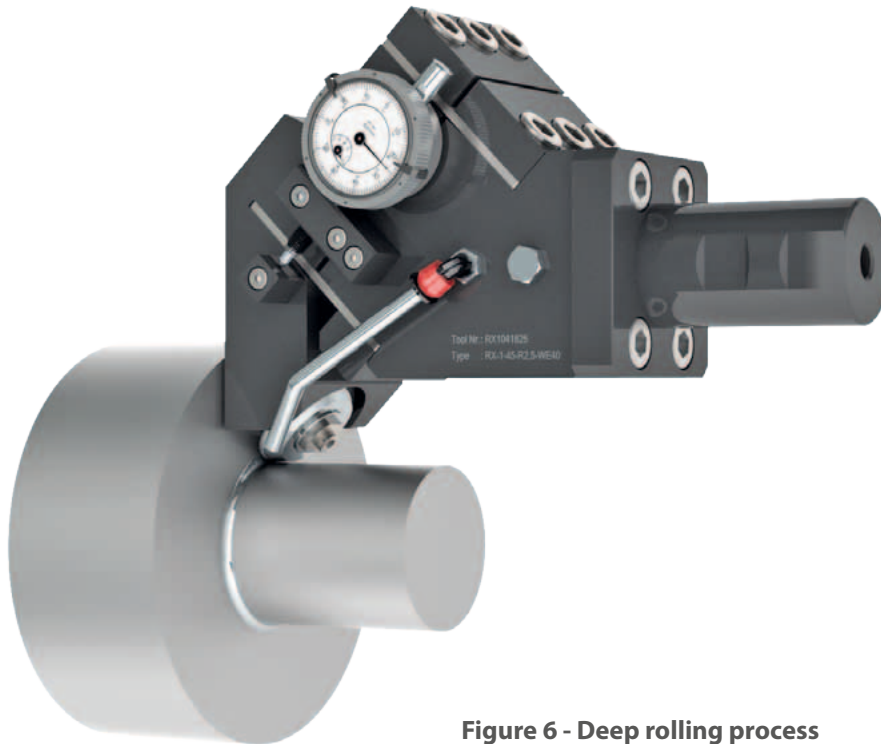

Figure 6 - Deep rolling process

Deep rolling operation

This method is generally used in the operation of narrow and difficult-to-access surfaces having radius $R < 4$ mm. Rolling force, through using profile deep rolling rollers, is implemented to radius, an area which will be exposed to metal fatigue. Adjustable deep rolling rollers, is automatically aligned with the slope of the workpiece. This considerably reliable operation calculates production tolerances and completely distributes remnant compression stress as it is demanded.

The Operation is realized through two motions;

1st Motion; Rotation: Workpiece rotates.

2nd Motion; Plunge-in: Deep rolling roller which is purpose-built according to radius profile is pressed onto radius with pre-determined force.

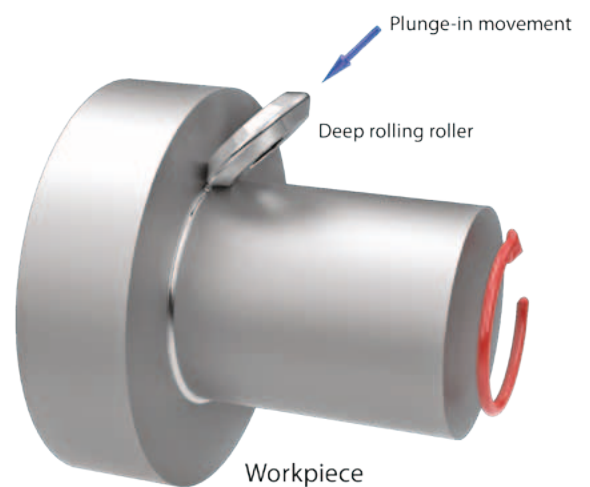

Figure 7 - Plunge-in process

Skive-Burnishing is used to finish process the inner surfaces of hydraulic-pneumatic cylinders and tubes. Tools complete skiving and burnishing operation in one pass. Since it is possible to produce quickly and economically high-quality tubes, this technology is preferred instead of honing method in serial production.

Roller burnished surfaces provide much more lower surface roughness according to the honed surfaces, in this case too low abrasion value occurs. Therefore, joints running through the cylinder are less worn and has long life. Also the optimal surface roughness is obtained too which is required for sealing. With this technology, tubes which have high surface quality, hardness and worn durable are produced, process time and costs are extremely decreased.

Skive-burnishing operation

Tools have a processing capacity reaching up to 5 meters/minute speed. Tools perform skiving-burnishing operation simultaneously. Thanks to this ultra fast tools processing times are extremely short;

Operation is generally carried on deep hole drilling machine. Machine is equipped with equipment and tool suitable for workpiece diameter and adjusted.

Knives on skiving head are activated as hydraulic unit is engaged. Tool is speedily progressed towards inside of the tube. Guiding pads bears the tube. Cutters at the back determine the finishing diameter and tolerance while pre-cutters mounted to knives are skiving the rough surface. Each knife removes same amount of sawdust from the tube. Removed sawdust are pushed forward by the highly compressed cooling oil supplied from the back. In this way, skiving head in the front prepares optimal size and surface by skiving excessive sawdust up to adjusted diameter for roller burnishing operation (R_z 5-20 μ m).

Roller head located at the back eliminates roughness of the surface by performing roller burnishing process and ensures final finishing size. Support pads feed on the finish surface.

Knives and roller head are shut down hydraulically.

Tool speedily retracted and operation is completed with one pass without leading any damage on the surface.

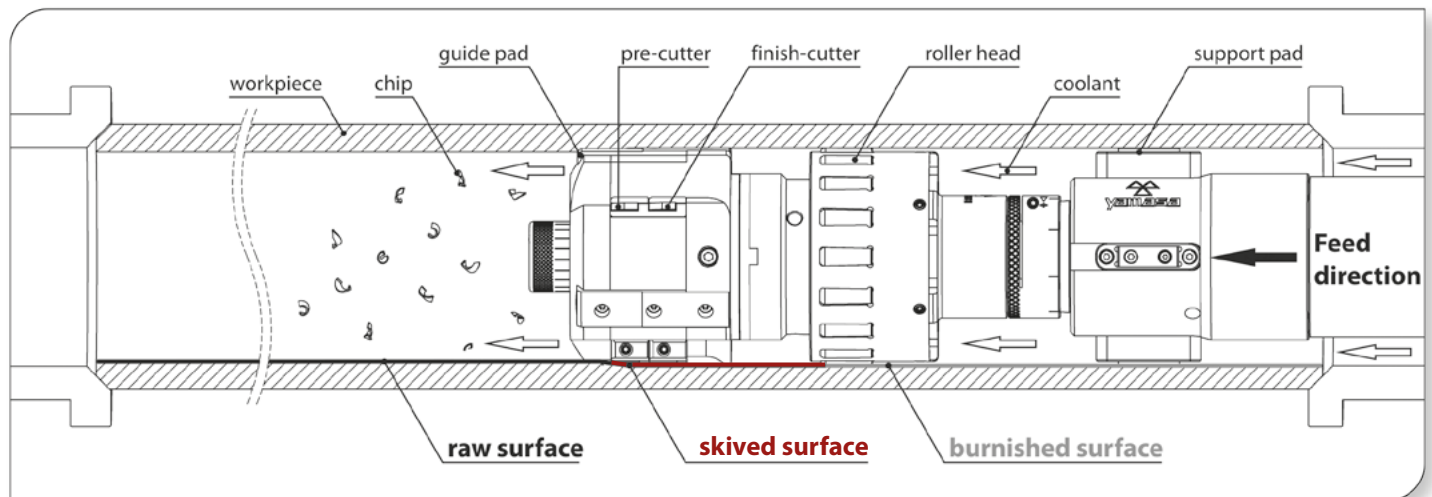

Figure 8 - Simultaneously skive-burnishing process

YAMASA skive-burnishing technology provides you many advantages;

You will save from wear parts!

- Long life wear parts will decrease your consumption drastically!
- The money you spend for wear parts decrease drastically!
- Replacements are easy, anyone can do it, no need any professionalism.

You will save time!

- Diameter adjustment with indicator provide time saving and convenience.
- High cutting performance minimize the machining time.
- The replacement of spare parts with longer periods shorten the machine down time.
- Minimized replacement duration provides time savings.

Skive-Burnishing Technology

You will produce high quality tubes in every conditions!!!

- It will produce quality tubes by eliminating rippling and axis alignment errors which source from machine.
- Excellent surface quality in one pass ($R_z < 1 \mu\text{m}$ / $R_a < 0,1 \mu\text{m}$).
- Provides improved cylindrical forms by reducing the circularity till 0,01 mm.
- Reduce rippling or remove completely.
- It can produce the tubes in large irregularities in one operation.
- High cutting depth offers a possibility of machining hot rolled tubes in one pass.

Your production cost will decrease drastically!

- When YAMASA CEO new generation combined skive-burnishing tools are began to used wear part needs and cost reduction immediately are noticed.
- Decrease in machine downtime and operation, increase in production amount affect production costs positively.

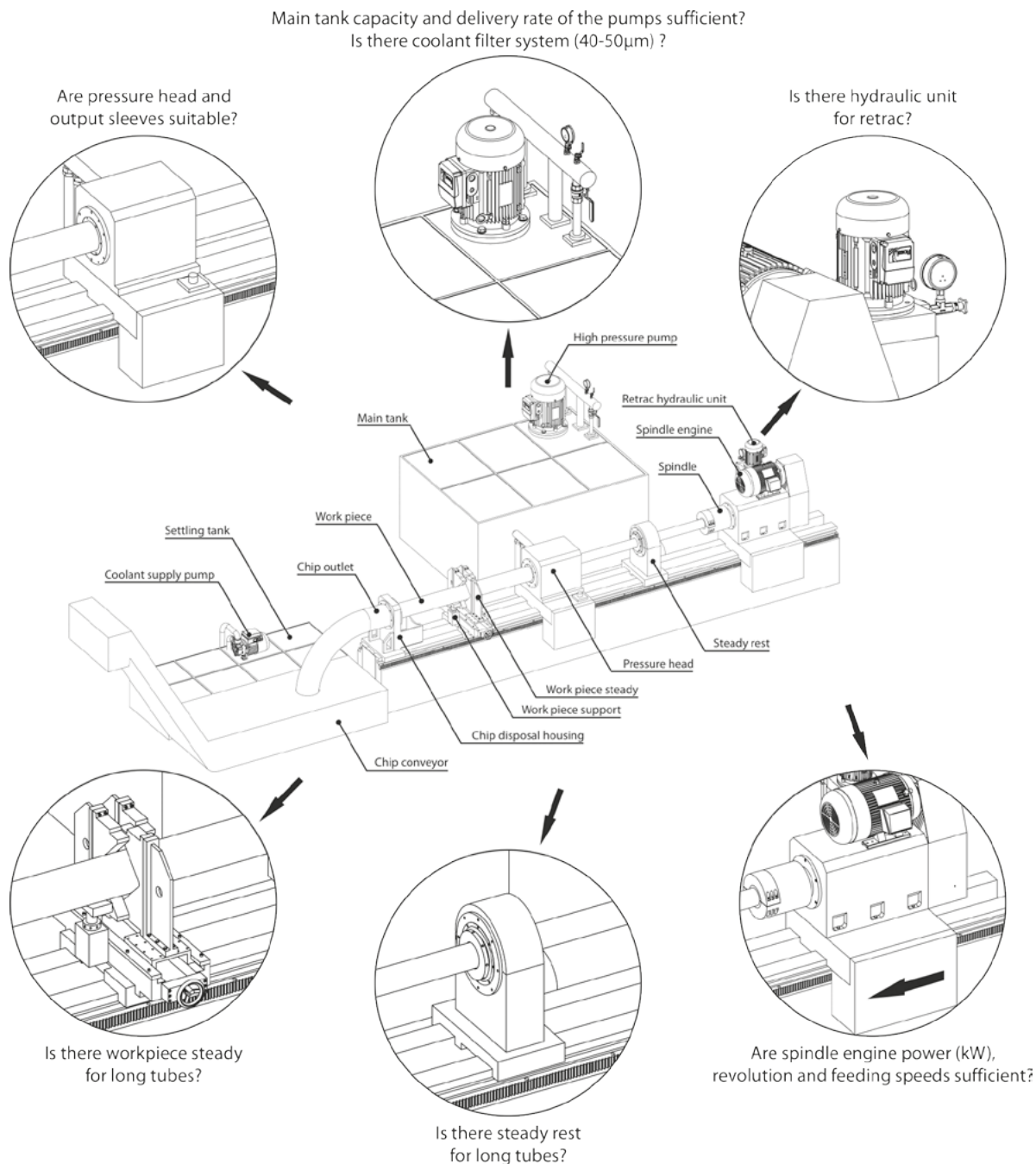

For the first-time users!

You can consult us for checking whether your current machine is suitable for the skive-burnishing system, for the necessary revisions to make it suitable, or for determining the additions. If you have such a request, please contact us. Our technical staff will provide you necessary help and information.

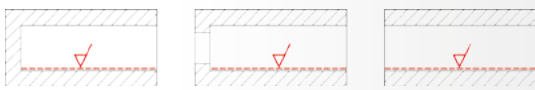

✓ Achievable surface roughness $Rz < 1\mu\text{m} / Ra < 0,16\mu\text{m}$

Internal Roller Burnishing Tools

Application

- Tools are used for the aim of burnishing through holes, semi-blind hole and blind holes.
- Provide surface hardness and calibration (measurement accuracy).
- Used on all kinds of machining production machines such as CNC and universal lathe, machining centers, drilling or milling machines, etc.
- Pre-machining and burnishing is possible on same machine. Process is done in one pass after pre-machining.

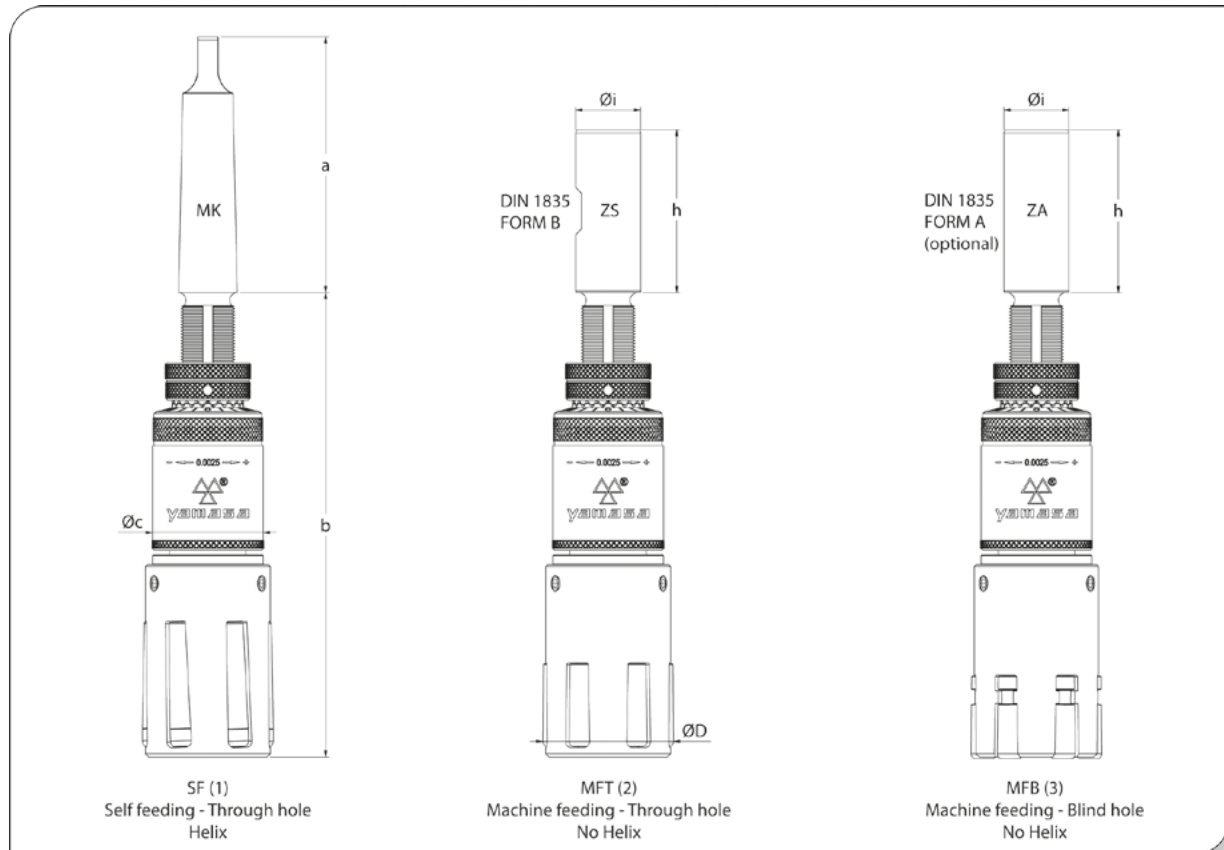

Tool Versions

There are three versions of YAMASA DX burnishing tools according to the process type.

Version 1: SF - Self feeding for through holes

- Burnish the through holes. It makes the feeding self. If the revolution increases the feeding speed increases self in the same rate.
- It is suitable for use such on universal lathe, drilling, milling machines.

Version 2: MFT - Machine feeding for through holes

- Burnish the through holes.
- It can be used on all kind of machining production machines.
- Feed rate: 0,05 - 0,3 mm/rev. per roller

Version 3: MFB - Machine feeding for blind holes

- Burnish the blind holes up to end. It can be used for also through holes and semi-blind holes.
- It can be used on all kind of machining production machines.
- Feed rate: 0,05 - 0,3 mm/rev. per roller

Tool body	Diameter range $\varnothing D$	Shank		Setting range			Dimensions			Remarks					
		Morse taper	Cylindrical- $\varnothing i \times h$	SF	MFT	MFB	a	b	c						
DX1.1	005,00	MK2 or MK1 (optional)	ZS20- $\varnothing 20 \times h \times 50$	-0,05 / +0,10	-0,05 / +0,10	-	78,5	146	34	Standard rolling length 50 mm.	Please look tool selection tables for other rolling lengths options.				
	006,00 - 008,00			-0,05 / +0,20	-0,05 / +0,20	-0,05 / +0,20									
	009,00 - 014,00			-0,10 / +0,40	-0,10 / +0,40	-0,05 / +0,40									
DX1.2	015,00 - 021,00			-0,10 / +0,90	-0,10 / +0,40	-0,05 / +0,40		78,5				140	Unlimited rolling length.	Please ask for special situations.	
	022,00 - 031,00											140			
DX1.3	032,00 - 034,00											MK3			ZS25- $\varnothing 25 \times h \times 56$
	035,00 - 049,00	143,5													
DX2	050,00 - 080,00	MK4	ZS32- $\varnothing 32 \times h \times 60$				98		177,5	48					
DX3	081,00 - 160,00						123		195	62					
DX4	161,00 - 350,00			MK5	ZS40- $\varnothing 40 \times h \times 70$	155,5	272,5	89							
						155,5	272,5	89							

All dimensions in mm. **SF(1):** Self feeding - through hole **MFT(2):** Machine feeding - through hole **MFB(3):** Machine feeding - blind hole

Internal Roller Burnishing Tools

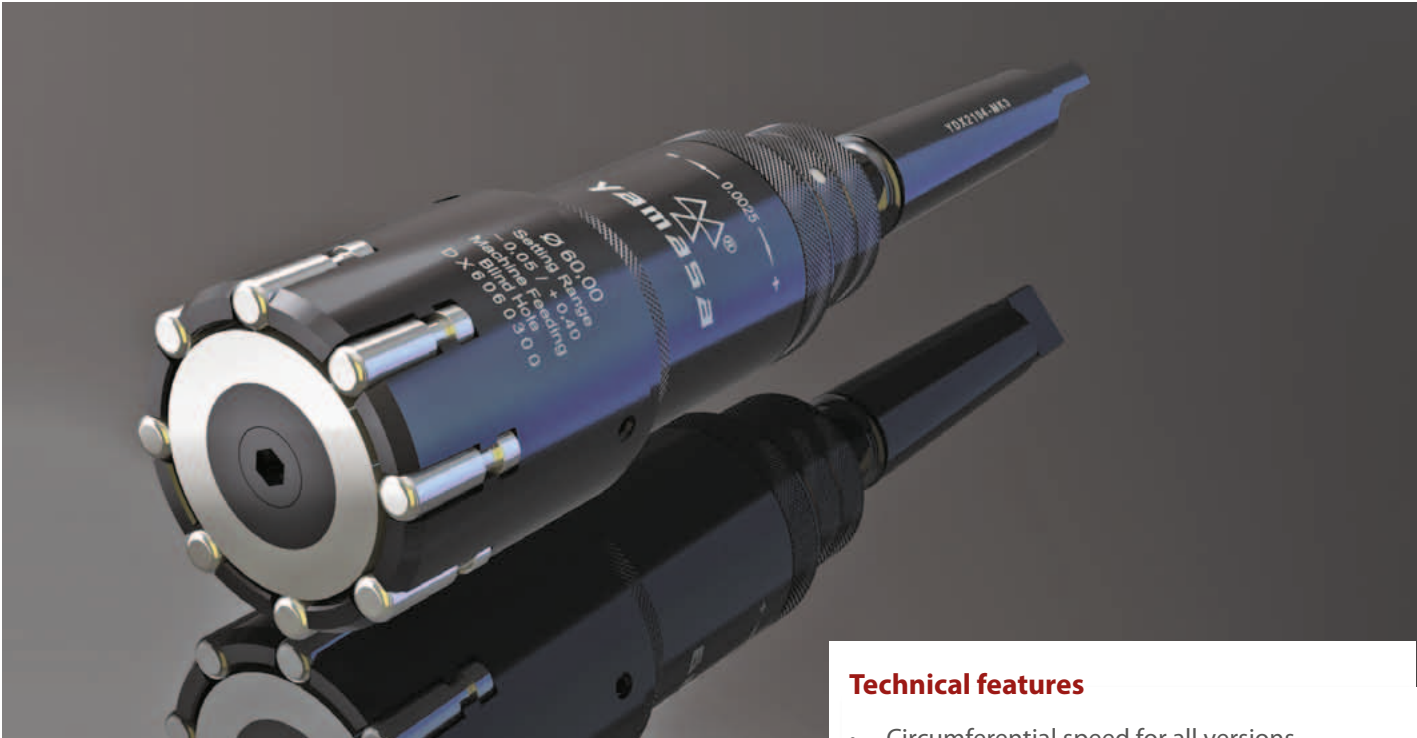

DX Series
Developed System



Technical features

- Circumferential speed for all versions maximum 250 m/min.
- Tools can be adjustable 0,15 - 1 mm according to type.
- Has a 0,0025 mm precise adjustment mechanism.
- Can burnish the holes up to H8-H9 tolerance with one adjustment.
- Burnishing all kinds of metallic materials up to the tensile strength of 1400N/mm² and to the hardness 42-45 HRC.
- Easy setting, long using life, low spare parts consumption. Every kind of spare part can be provided by YAMASA.

Tool structure

- Tool consists of a burnishing head and a body which has a precision adjustment mechanism.
- Burnishing head consists of a cage, cone and rollers. In the same time, these are consumables.
- It is possible to mount on the same type body the roller heads in different diameter.
- There are cylindrical and morse taper shank choices are available for machine connection (see table).



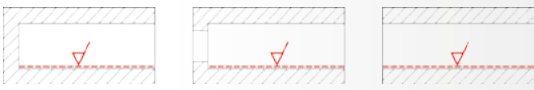

✓ Achievable surface roughness $Rz < 1 \mu m / Ra < 0,16 \mu m$

DX Type | Between $\varnothing 5 - 14 \text{ mm}$

Internal Roller Burnishing Tools

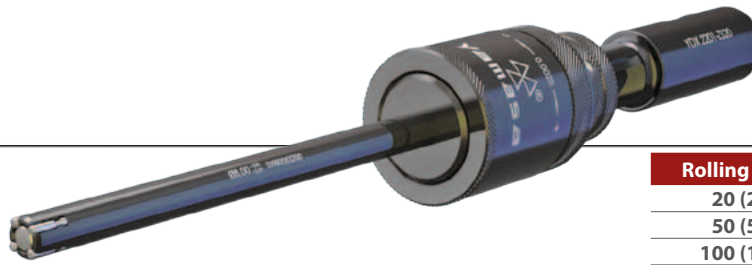

Rolling length	e	f
20 (23*)	27	74,5
50 (58*)	62	84
100 (108*)	112	84
150 (158*)	162	84

*max. rolling length for blind hole tool

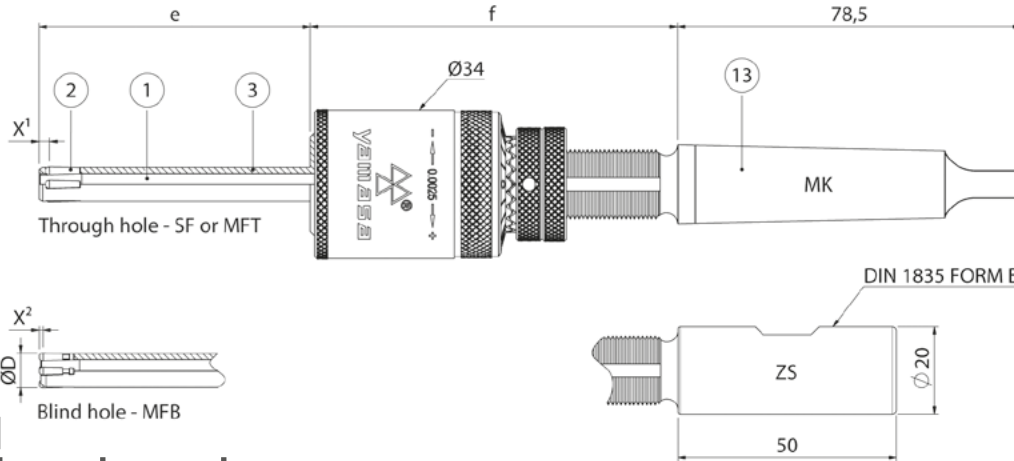

Minimum edge

Diameter range	X ¹ / SF	X ¹ / MFT	X ² / MFB
05,00	2,4	2,4	-
06,00 - 14,00	2,6	2,6	0,8

X²: It is possible to come to near the edge more. Please ask for special situations.

- 1- Cone
- 2- Roller
- 3- Cage
- 13- Shank

Recommended machining parameters

Diameter range (mm)	Revolution (rev/min)	Feed rate (mm/rev)	Feeding (mm/min)	Rotation direc.	Rolling share	Pre-machining roughness	Pre-machining	Coolant
				Retreat	Tool preload			
05,00	1000	0,30	300	CCW (M3)	up to 0,02 mm	Rz = 5 - 15 μm	Reaming or lathe	Oil or emulsion
06,00 - 07,00	1000	0,45	450	Rapidly (G0)	up to 0,05 mm			
08,00 - 14,00	1000	0,60	600					

Product selection

DX Tool selection (complete)						Spare part selection																	
Tool body	Dia. \varnothing -mm	Version			Rolling length	Shank	DX Cage				DX Cone				Roller			Qua.					
		SF	MFT	MFB			Dia. \varnothing -mm	Version	Rolling length	Dia. \varnothing -mm	Version	Rolling length	SF	MFT	MFB								
DX1.1	5,00	1	2	3	20	MK2 or MK1 (opt.)	ZS20 or ZA20 (opt.)	1	2	3	20	1	2	3	20	500115	500115	-	3				
	50				5,00						5,00				50								
	6,00				20 . 50						6,00				20 . 50					6,00	500100	500100	500308
	7,00				100						7,00				100					7,00	500108	50108	500300
	8,00				20						8,00				20					8,00	500102	500102	500301
	9,00				50						9,00				50								
	10,00				100						10,00				100								
	11,00				150						11,00				150								
	12,00				20						12,00				20					12,00			
	13,00				50						13,00				50					13,00			
14,00	100	14,00	100	14,00																			
	150		150																				

How to order | Order samples

DX1.1-12,00-1-50-MK2 Roller burnishing tool	12,00-1-50 DX Cage	12,00-1-50 DX Cone	500102 Roller
---	--------------------	--------------------	---------------

You can create order codes of the tool and spare parts by looking at the product selection table. For this, please rank the requested product features side by side.

All dimensions in mm. **SF(1):** Self feeding - through hole **MFT(2):** Machine feeding - through hole **MFB(3):** Machine feeding - blind hole

Internal Roller Burnishing Tools



Rolling length	e	f
50 (64*)	69	77
100 (114*)	119	78,5
150 (164*)	169	78,5
200 (214*)	219	78,5
250 (264*)	269	78,5

*max. rolling length for blind hole tool

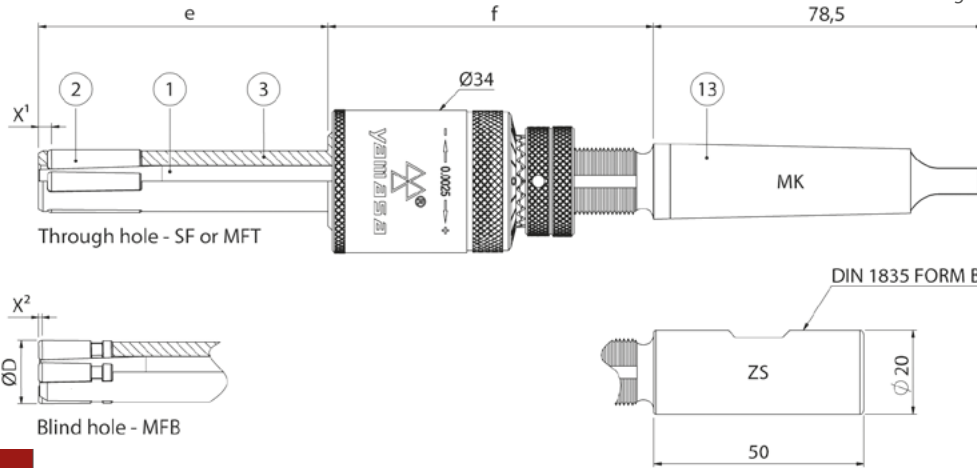

- 1- Cone
- 2- Roller
- 3- Cage
- 13- Shank

Minimum edge

Diameter range	X ¹ / SF	X ¹ / MFT	X ² / MFB
15,00 - 21,00	6,2	3,5	0,8

X²: It is possible to come to near the edge more. Please ask for special situations.

Recommended machining parameters

Diameter range (mm)	Revolution (rev/min)	Feed rate (mm/rev)	Feeding (mm/min)	Rotation direc.	Rolling share	Pre-machining roughness	Pre-machining	Coolant
				Retreat	Tool preload			
015,00 - 021,00	1000	0,75	750	CCW (M3)	up to 0,02 mm	Rz = 5 - 15 µm	Reaming or lathe	Oil or emulsion
				Rapidly (G0)	up to 0,05 mm			

Product selection

DX Tool selection (complete)							Spare part selection														
Tool body	Dia. Ø-mm	Version			Rolling length	Shank		DX Cage				DX Cone				Roller			Qua.		
		SF	MFT	MFB		Dia. Ø-mm	Version	Rolling length	Dia. Ø-mm	Version	Rolling length	Code									
								SF	MFT	MFB		SF	MFT	MFB		SF	MFT	MFB			
DX1.2	15,00	1	2	3	50 · 100 · 150 · 200 · 250	MK2 or MK1 (opt.)	ZS20 or ZA20 (opt.)	15,00	1	2	3	50 · 100 · 150 · 200 · 250	15,00	1	2	3	-	500129	500111	500310	5
	16,00							16,00													
	17,00							17,00													
	18,00							18,00													
	19,00							19,00					500130					500112	500311		
	20,00							20,00													
	21,00							21,00													

How to order | Order samples

DX1.2-15,00-2-50-ZS20 Roller burnishing tool	15,00-2-50 DX Cage	15,00-2 DX Cone	500111 Roller
--	--------------------	-----------------	---------------

You can create order codes of the tool and spare parts by looking at the product selection table. For this, please rank the requested product features side by side. All dimensions in mm. **SF(1)**: Self feeding - through hole **MFT(2)**: Machine feeding - through hole **MFB(3)**: Machine feeding - blind hole

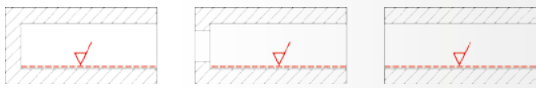

✓ Achievable surface roughness $Rz < 1 \mu\text{m}$ / $Ra < 0,16 \mu\text{m}$

DX Type | Between $\varnothing 22 - 31 \text{ mm}$

Internal Roller Burnishing Tools



Rolling length	e	f
50 (59*)	63,5	76,5
100 (109*)	113,5	78
150 (159*)	163,5	78
200 (209*)	213,5	78
250 (259*)	263,5	78
300 (309*)	313,5	78

*max. rolling length for blind hole tool

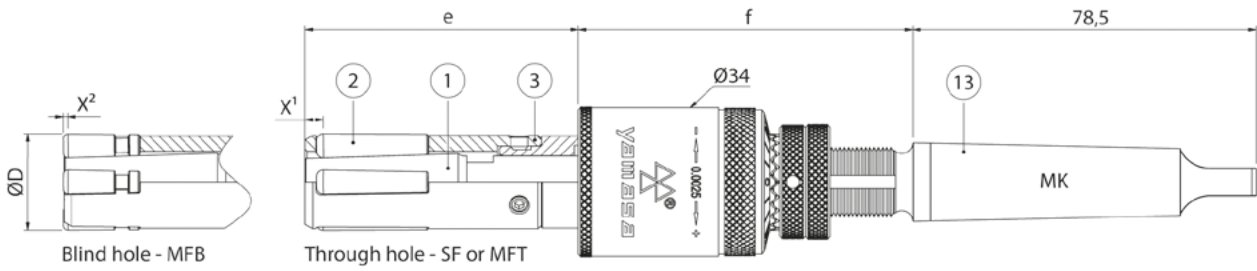

Minimum edge

Diameter range	X ¹ / SF	X ¹ / MFT	X ² / MFB
22,00 - 27,00	7,7	5,5	0,8
28,00 - 31,00	9,3	5,5	0,8

X²: It is possible to come to near the edge more. Please ask for special situations.

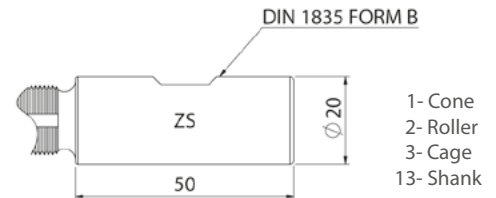

Recommended machining parameters

Diameter range (mm)	Revolution (rev/min)	Feed rate (mm/rev)	Feeding (mm/min)	Rotation direc.	Rolling share	Pre-machining roughness	Pre-machining	Coolant
				Retreat	Tool preload			
022,00 - 031,00	1000	0,75	750	CCW (M3)	up to 0,03 mm	Rz = 5 - 20 μm	Reaming or lathe	Oil or emulsion
				Rapidly (G0)	up to 0,06 mm			

Product selection

DX Tool selection (complete)							Spare part selection												
Tool body	Dia. \varnothing -mm	Version			Rolling length	Shank		DX Cage				DX Cone				Roller			Qua.
		SF	MFT	MFB		Dia. \varnothing -mm	Version	Rolling length	Dia. \varnothing -mm	Version	Rolling length	Code							
DX1.2	22,00	1	2	3	50 · 100 · 150 · 200 · 250 · 300	MK2 or MK1 (opt.)	ZS20 or ZA20 (opt.)	1	2	3	-	1	2	3	-	500130	500112	500311	5
	23,00																		
	24,00																		
	25,00																		
	26,00																		
	27,00																		
	28,00																		
	29,00																		
	30,00																		
	31,00																		

How to order | Order samples

DX1.2-22,00-3-50-ZS20 Roller burnishing tool	22,00-3 DX Cage	22,00-3 DX Cone	500311 Roller
--	-----------------	-----------------	---------------

You can create order codes of the tool and spare parts by looking at the product selection table. For this, please rank the requested product features side by side. All dimensions in mm. **SF(1)**: Self feeding - through hole **MFT(2)**: Machine feeding - through hole **MFB(3)**: Machine feeding - blind hole

Internal Roller Burnishing Tools



Rolling length	e	f
50 (59*)	63,5	76,5
100 (109*)	113,5	78
150 (159*)	163,5	78
200 (209*)	213,5	78
250 (259*)	263,5	78
300 (309*)	313,5	78

*max. rolling length for blind hole tool

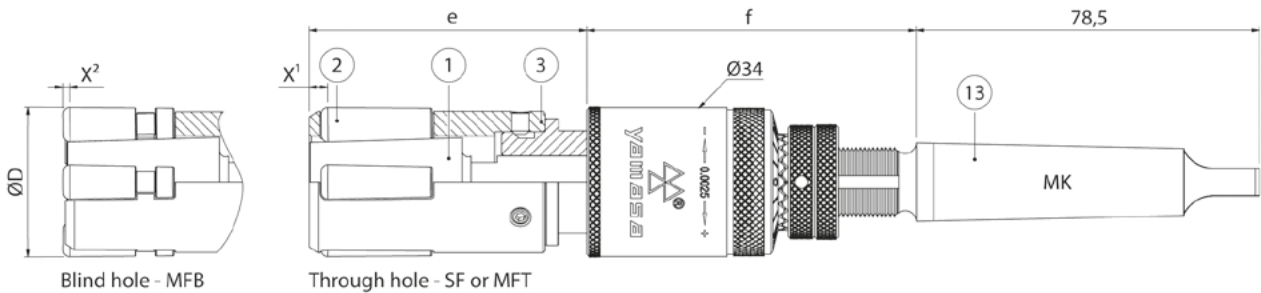

Minimum edge

Diameter range	X ¹ / SF	X ¹ / MFT	X ² / MFB
32,00 - 34,00	9,3	5,5	0,8

X²: It is possible to come to near the edge more. Please ask for special situations.

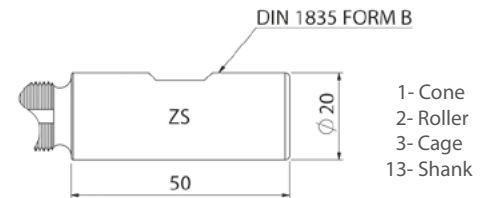

Recommended machining parameters

Diameter range (mm)	Revolution (rev/min)	Feed rate (mm/rev)	Feeding (mm/min)	Rotation direc.	Rolling share	Pre-machining roughness	Pre-machining	Coolant
				Retreat	Tool preload			
032,00 - 034,00	950	0,75	710	CCW (M3)	up to 0,03 mm	Rz = 5 - 20 µm	Reaming or lathe	Oil or emulsion
				Rapidly (G0)	up to 0,06 mm			

Product selection

DX Tool selection (complete)							Spare part selection														
Tool body	Dia. Ø-mm	Version			Rolling length	Shank		DX Cage				DX Cone				Roller			Qua.		
		SF	MFT	MFB				Dia. Ø-mm	Version	Rolling length	Dia. Ø-mm	Version	Rolling length	Code							
								SF	MFT	MFB		SF	MFT	MFB		SF	MFT	MFB			
DX1.3	32,00	1	2	3	50 · 100 · 150 · 200 · 250 · 300	MK2 or MK1 (opt.)	ZS20 or ZA20 (opt.)	32,00	1	2	3	-	32,00	1	2	3	-	500128	500109	500307	5
	33,00							33,00					33,00								
	34,00							34,00					34,00								

How to order | Order samples

DX1.3-32,00-1-100-MK2 Roller burnishing tool	32,00-1 DX Cage	32,00-1 DX Cone	500128 Roller
--	-----------------	-----------------	---------------

You can create order codes of the tool and spare parts by looking at the product selection table. For this, please rank the requested product features side by side. All dimensions in mm. **SF(1)**: Self feeding - through hole **MFT(2)**: Machine feeding - through hole **MFB(3)**: Machine feeding - blind hole

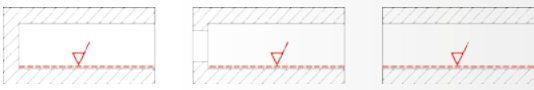

✓ Achievable surface roughness $Rz < 1 \mu m$ / $Ra < 0,16 \mu m$

DX Type | Between $\varnothing 35 - 49 \text{ mm}$

Internal Roller Burnishing Tools

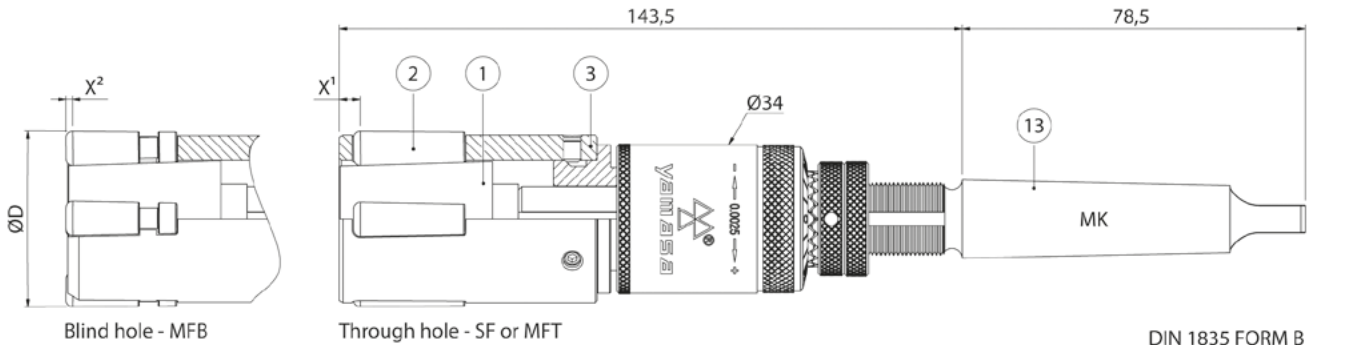

Minimum edge

Diameter range	X ¹ / SF	X ¹ / MFT	X ² / MFB
35,00 - 49,00	9,3	5,5	0,8

X²: It is possible to come to near the edge more. Please ask for special situations.

Recommended machining parameters

Diameter range (mm)	Revolution (rev/min)	Feed rate (mm/rev)	Feeding (mm/min)	Rotation direc.	Rolling share	Pre-machining roughness	Pre-machining	Coolant
				Retreat	Tool preload			
035,00 - 040,00	800	0,90	720	CCW (M3)	up to 0,03 mm	Rz = 5 - 20 μm	Reaming or lathe	Oil or emulsion
041,00 - 049,00	650	0,90	580	Rapidly (G0)	up to 0,06 mm			

Product selection

DX Tool selection (complete)								Spare part selection													
Tool body	Dia. \varnothing -mm	Version			Rolling length			Shank		DX Cage			DX Cone			Roller			Qua.		
		SF	MFT	MFB	SF	MFT	MFB			SF	MFT	MFB	SF	MFT	MFB	SF	MFT	MFB			
DX1.3	35,00	1	2	3	stand. U=128	stand. U=132	stand. U=137	MK2 or MK1 (opt.)	ZS20 or ZA20 (opt.)	35,00	1	2	3	35,00	1	2	3	500128	500109	500307	6
	36,00									36,00											
	37,00									37,00											
	38,00									38,00											
	39,00									39,00											
	40,00									40,00											
	41,00									41,00											
	42,00									42,00											
	43,00									43,00											
	44,00									44,00											
	45,00									45,00											
	46,00									46,00											
	47,00									47,00											
	48,00									48,00											
	49,00									49,00											

How to order | Order samples

DX1.3-35,00-2-U-ZS20 Roller burnishing tool	35,00-2 DX Cage	35,00-2 DX Cone	500109 Roller
---	-----------------	-----------------	---------------

You can create order codes of the tool and spare parts by looking at the product selection table. For this, please rank the requested product features side by side. All dimensions in mm. **SF(1)**: Self feeding - through hole **MFT(2)**: Machine feeding - through hole **MFB(3)**: Machine feeding - blind hole

Internal Roller Burnishing Tools

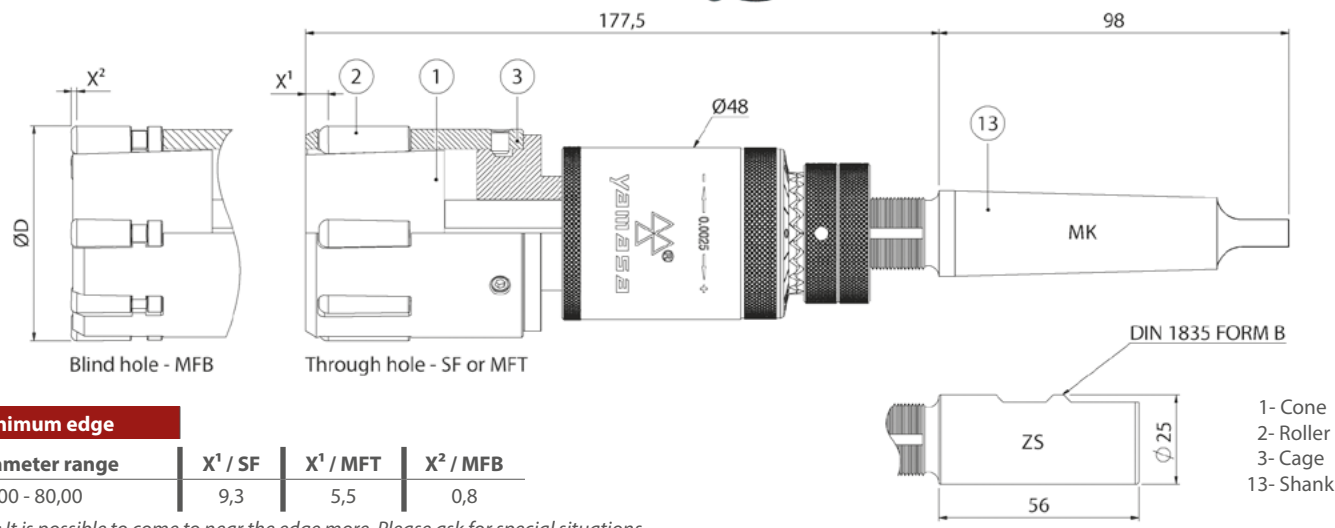

Minimum edge

Diameter range	X ¹ / SF	X ¹ / MFT	X ² / MFB
50,00 - 80,00	9,3	5,5	0,8

X²: It is possible to come to near the edge more. Please ask for special situations.

Recommended machining parameters

Diameter range (mm)	Revolution (rev/min)	Feed rate (mm/rev)	Feeding (mm/min)	Rotation direc.	Rolling share	Pre-machining roughness	Pre-machining	Coolant
				Retreat	Tool preload			
050,00 - 060,00	530	1,20	630	CCW (M3)	up to 0,04 mm	Rz = 5 - 30 µm	Reaming or lathe	Oil or emulsion
061,00 - 070,00	450	1,20	540					
071,00 - 080,00	400	1,20	480	Rapidly (G0)	up to 0,07 mm			

Product selection

DX Tool selection (complete)									Spare part selection												
Tool body	Dia. Ø-mm	Version			Rolling length			Shank	DX Cage			DX Cone			Roller			Qua.			
		SF	MFT	MFB	SF	MFT	MFB		Dia. Ø-mm	Version	Dia. Ø-mm	Version	SF	MFT	MFB	SF	MFT		MFB		
DX2	50,00	1	2	3	stand.	stand.	stand.	MK3	ZS25 or ZA25 (opt.)	50,00	1	2	3	50,00	1	2	3	500128	500109	500307	8
	55,00				U=163	U=167	U=173			55,00				55,00							
	60,00				long	long	long			60,00				60,00							
	65,00				210	210	210			65,00				65,00							
	70,00				250	250	250			70,00				70,00							
	75,00				300	300	300			75,00				75,00							
	80,00				350	350	350			80,00				80,00							
					400	400	400														
	450	450	450																		
	500	500	500																		
	550	550	550																		

How to order | Order samples

DX2-52,00-3-U-ZS25 Roller burnishing tool	52,00-3 DX Cage	52,00-3 DX Cone	500307 Roller
---	-----------------	-----------------	---------------

You can create order codes of the tool and spare parts by looking at the product selection table. For this, please rank the requested product features side by side. All dimensions in mm. **SF(1)**: Self feeding - through hole **MFT(2)**: Machine feeding - through hole **MFB(3)**: Machine feeding - blind hole

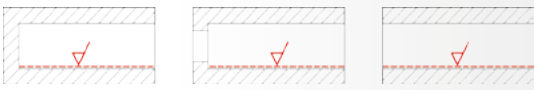

✓ Achievable surface roughness $Rz < 1 \mu\text{m}$ / $Ra < 0,16 \mu\text{m}$

DX Type | Between $\varnothing 81 - 160 \text{ mm}$

Internal Roller Burnishing Tools

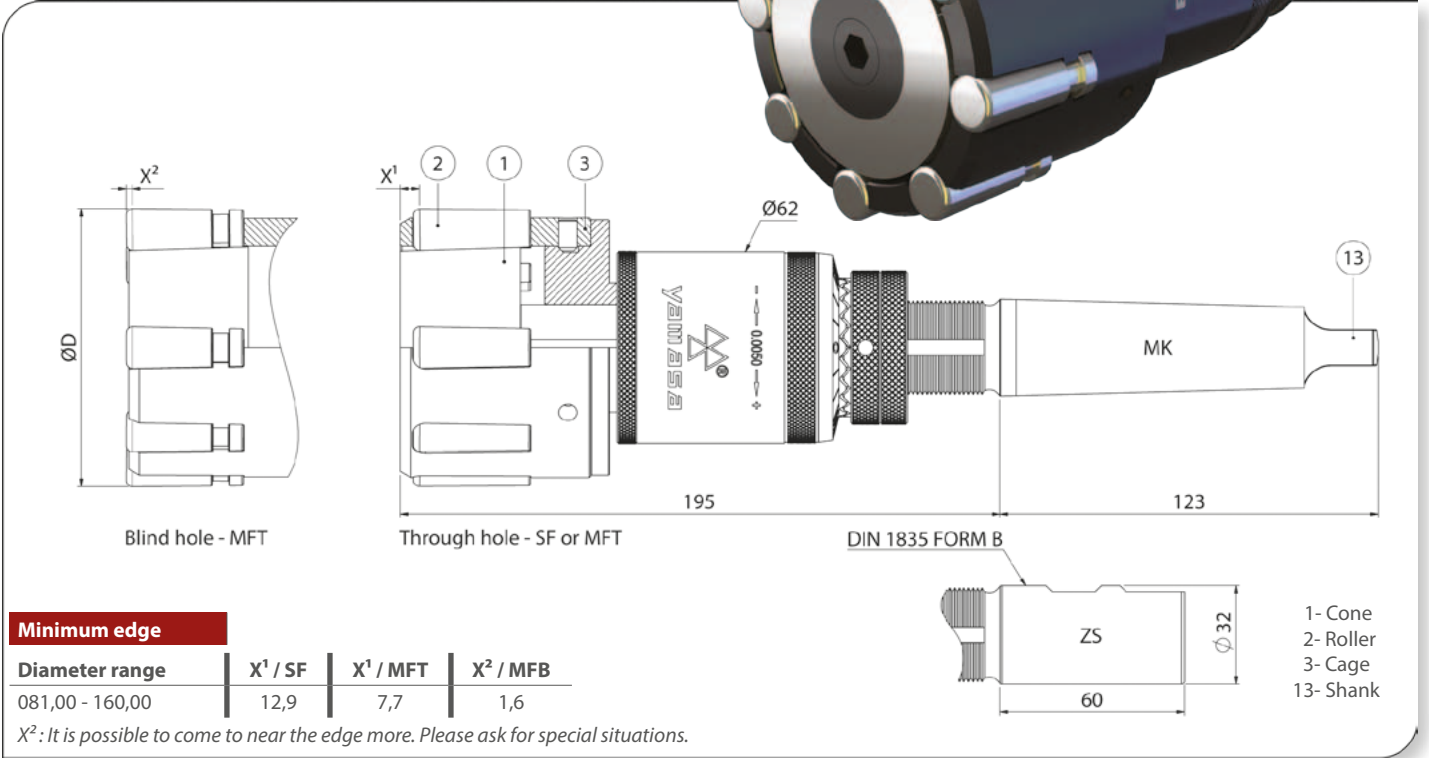

Minimum edge

Diameter range	X¹ / SF	X¹ / MFT	X² / MFB
081,00 - 160,00	12,9	7,7	1,6

X²: It is possible to come to near the edge more. Please ask for special situations.

Recommended machining parameters

Diameter range (mm)	Revolution (rev/min)	Feed rate (mm/rev)	Feeding (mm/min)	Diameter range (mm)	Revolution (rev/min)	Feed rate (mm/rev)	Feeding (mm/min)	Rotation direction	Retreat	Rolling share	Tool preload	Pre-machining rough.	Pre-machining	Coolant
081,00 - 090,00	350	1,20	420	121,00 - 140,00	230	1,50	340	CCW (M3)	Rapidly (G0)	up to 0,05 mm	up to 0,10 mm	$Rz = 5 - 30 \mu\text{m}$	Reaming or lathe	Oil or emulsion
091,00 - 100,00	320	1,20	380	141,00 - 150,00	210	1,50	310							
101,00 - 120,00	260	1,20	310	151,00 - 160,00	200	1,80	360							

Product selection

DX Tool selection (complete)								Spare part selection								Qua.					
Tool body	Dia. \varnothing -mm	Version			Rolling length			Shank	DX Cage			DX Cone			Roller						
		SF	MFT	MFB	SF	MFT	MFB		Dia. \varnothing -mm	SF	MFT	MFB	Dia. \varnothing -mm	SF	MFT		MFB	SF	MFT	MFB	
DX3	081,00	1	2	3	stand. U=177	stand. U=182	stand. U=190	MK4	ZS32 or ZA32 (opt.)	81,00	1	2	3	81,00	1	2	3	500132	500107	500306	8
	090,00									90,00											
	100,00									100,00											
	110,00									110,00											
	120,00									120,00											
	121,00									121,00											
	130,00									130,00											
	140,00									140,00											
	150,00									150,00											
	151,00									151,00											
	160,00									160,00				10							
	160,00									160,00											12

How to order | Order samples

DX3-85,00-3-U-ZS32 Roller burnishing tool	85,00-3 DX Cage	85,00-3 DX Cone	500306 Roller
---	-----------------	-----------------	---------------

You can create order codes of the tool and spare parts by looking at the product selection table. For this, please rank the requested product features side by side. All dimensions in mm. **SF(1):** Self feeding - through hole **MFT(2):** Machine feeding - through hole **MFB(3):** Machine feeding - blind hole

Internal Roller Burnishing Tools

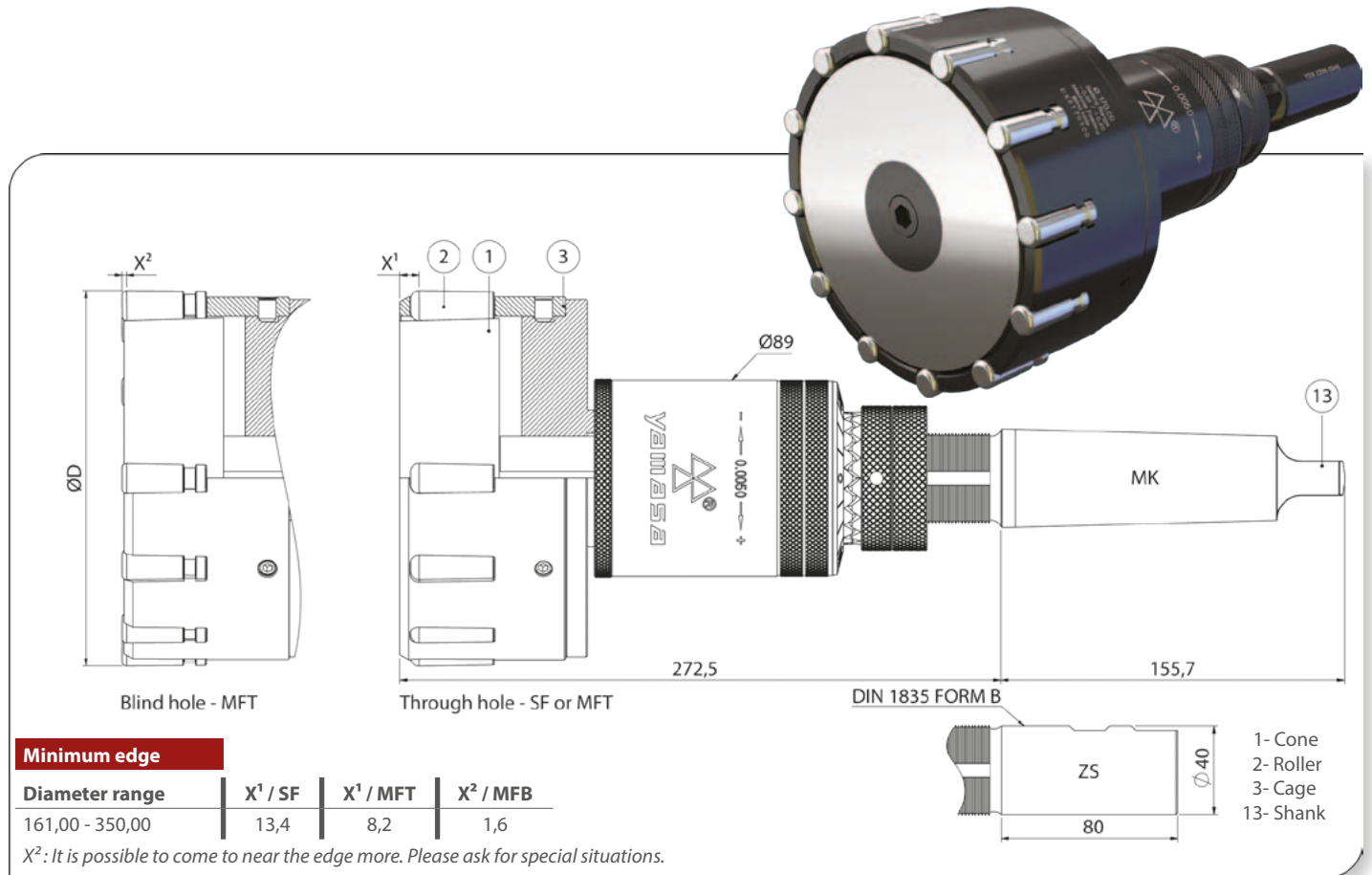

Minimum edge			
Diameter range	X ¹ / SF	X ¹ / MFT	X ² / MFB
161,00 - 350,00	13,4	8,2	1,6

X²: It is possible to come to near the edge more. Please ask for special situations.

Recommended machining parameters

Diameter range (mm)	Revolution (rev/min)	Feed rate (mm/rev)	Feeding (mm/min)	Diameter range (mm)	Revolution (rev/min)	Feed rate (mm/rev)	Feeding (mm/min)	Rotation direction	CCW (M3)
161,00 - 170,00	190	1,80	340	261,00 - 280,00	110	3,00	330	Retreat	Rapidly (G0)
171,00 - 200,00	160	2,10	330	281,00 - 310,00	100	3,30	330	Rolling share	up to 0,06 mm
201,00 - 260,00	140	2,40	330	311,00 - 350,00	95	3,60	340	Tool preload	up to 0,10 mm
								Pre-machining rough.	Rz = 5 - 30 µm
								Pre-machining	Reaming or lathe
								Coolant	Oil or emulsion

Product selection

DX Tool selection (complete)									Spare part selection												
Tool body	Dia. Ø-mm	Version			Rolling length			Shank	DX Cage			DX Cone			Roller			Qua.			
		SF	MFT	MFB	SF	MFT	MFB		Dia. Ø-mm	Version	Dia. Ø-mm	Version	Code	SF	MFT	MFB					
DX4	161,00	1	2	3	stand. U=254	stand. U=259	stand. U=266	MK5	ZS40 or ZA40 (opt.)	161,00	1	2	3	161,00	1	2	3	500132	500107	500306	12
	170,00									170,00				14							
	171,00									171,00				14							
	200,00									200,00				16							
	201,00									201,00				16							
	230,00									230,00				16							
	231,00									231,00				18							
	260,00									260,00				18							
	261,00									261,00				20							
	280,00									280,00				20							
	281,00									281,00				22							
	310,00									310,00				22							
	311,00									311,00				24							
	330,00									330,00				24							
	331,00									331,00				26							
	350,00									350,00				26							

How to order | Order samples

DX4-161,00-3-U-ZS40 Roller burnishing tool	161,00-3 DX Cage	161,00-3 DX Cone	500306 Roller
--	------------------	------------------	---------------

You can create order codes of the tool and spare parts by looking at the product selection table. For this, please rank the requested product features side by side. All dimensions in mm. **SF(1)**: Self feeding - through hole **MFT(2)**: Machine feeding - through hole **MFB(3)**: Machine feeding - blind hole

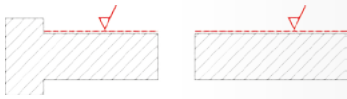

✓ Achievable surface roughness $Rz < 1 \mu\text{m} / Ra < 0,16 \mu\text{m}$

Explanations

External Roller Burnishing Tools

Application

- Tools are used for the aim of burnishing plain and stepped shafts.
- Provide surface hardness and at low rate calibration (measurement accuracy).
- Used on all kinds of machining production machines such as CNC and universal lathe machines, machining centers, drilling or milling machines.
- Pre-machining and burnishing is possible on same machine. Process is done in one pass after pre-machining.

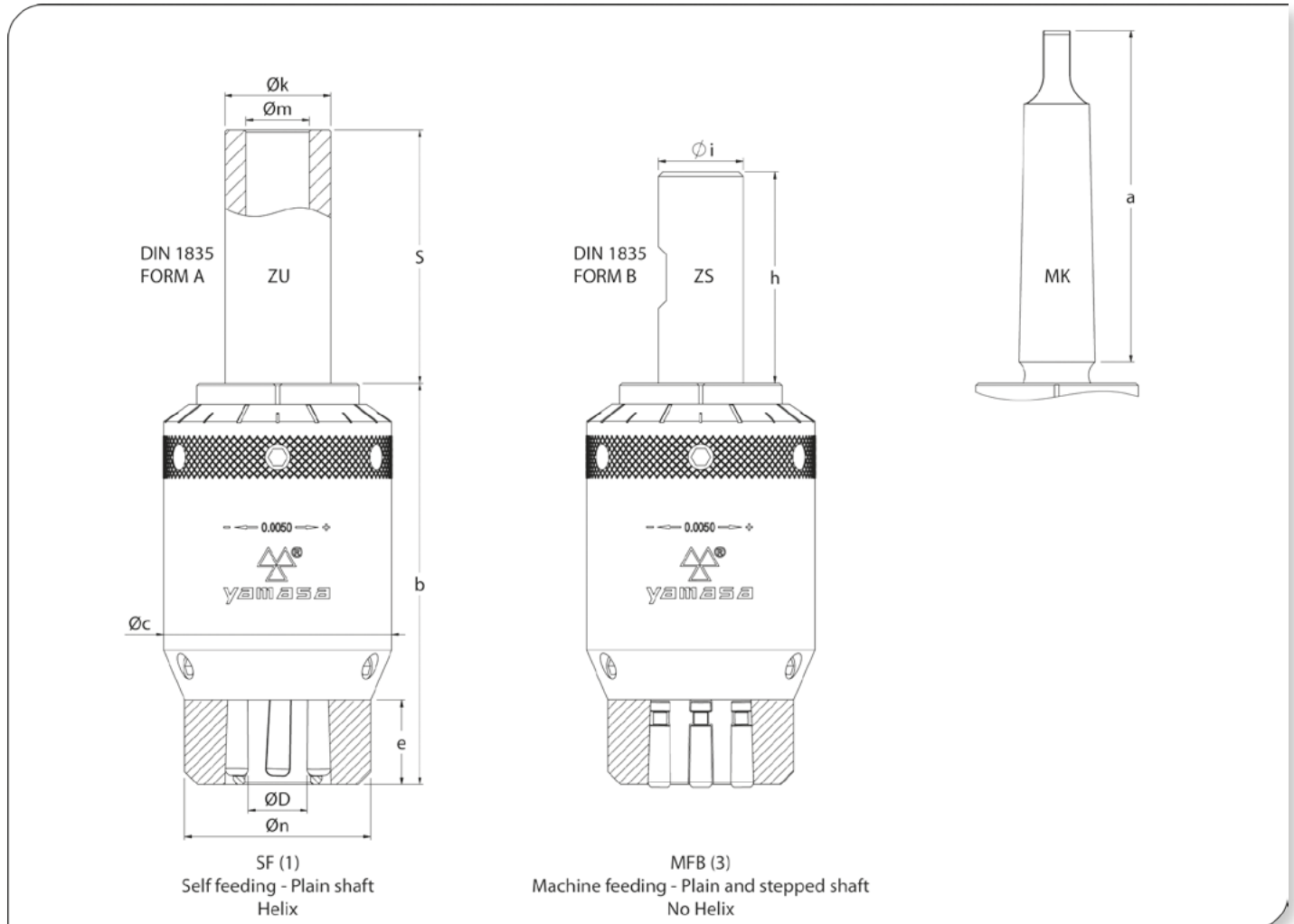

Tool Versions

There are two versions of YAMASA MX burnishing tools according to the process type.

Version 1: SF - Self feeding for plain shaft

- Burnish the plain shafts. It makes the feeding self. If the revolution increases the feeding speed increases self in the same rate.
- It is suitable for use such on universal lathe, drilling, milling machines.

Version 3: MFB - Machine feeding for plain-stepped shafts

- Burnish the plain and stepped shafts up to the end.
- It can be used on all kind of machining production machines.
- Feed rate: 0,05 - 0,3 mm/rev. per roller

Circumferential speed for all versions: max. 250 m/min.

Tool body	Dia.range ØD	Shank			Setting range		Dimensions				
		Morse taper	Cylindrical-Øixh	Cylindrical-ØkxSxØm	SF	MFB	a	b	c	e	n
MX1	001 - 014	MK2	ZS20-Ø20h6x50	ZU25-Ø25h6x60xØ15	-0,40/+0,10	-0,40/+0,05	78,5	min.095 - max.105	54	20	44
MX2	015 - 024	MK3	ZS25-Ø25h6x56	ZU40-Ø40h6x70xØ26			98	min.100 - max.110	74	20	62
MX3	025 - 049	MK4	ZS40-Ø40h6x70	ZU80-Ø80h6x90xØ50			123	min.119 - max.129	106	30	94
MX4	050 - 085			ZU110-Ø110h6x110xØ87			123	min.128 - max.138	149	30	138
MX5	086 - 110	MK5	ZS50-Ø50h6x80	ZU150-Ø150h6x120xØ112			155,5	min.141 - max.151	193	37	177
MX6	111 - 160			ZU180-Ø180h6x140xØ143			155,5	min.155 - max.165	237	37	222
MX7	141 - 160			ZU190-Ø190h6x150xØ163			155,5	min.159 - max.169	267	37	252

All dimensions in mm. **SF(1):** Self feeding - plain shaft **MFB(3):** Machine feeding - plain and stepped shaft

External Roller Burnishing Tools



- Technical features**
- Tools can be adjustable 0,45 - 0,50 mm according to type.
 - Has a 0,001 mm precise adjustment mechanism.
 - Can burnish the shafts up to H7 tolerance with one adjustment.
 - Burnishing all kinds of metallic materials up to the tensile strength of 1400N/mm² and to the hardness 42-45 HRC.
 - Easy setting, long using life, low spare parts consumption. Every kind of spare part can be provided by YAMASA.
- Tool structure**
- Tool consists of a burnishing head and a body which has a precision adjustment mechanism.
 - Burnishing head consists of a cage, cone and rollers. In the same time, these are consumables.
 - It is possible to mount on the same type body the roller heads in different diameter.
 - There are cylindrical and morse taper shank choices are available. Roller length is limited on the cylindrical and morse taper shanks choices. Please prefer ZU Shanks for unlimited roller lengths (see table).

MX Series
Developed System



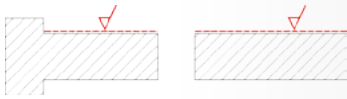

✓ Achievable surface roughness $Rz < 1\mu\text{m} / Ra < 0,16\mu\text{m}$

External Roller Burnishing Tools



Minimum edge

Diameter range	X ¹ / SF	X ² / MFB
001,00 - 004,00	3,2	0,8
005,00 - 014,00	7,2	0,8

X²: It is possible to come to near the edge more. Please ask for special situations.

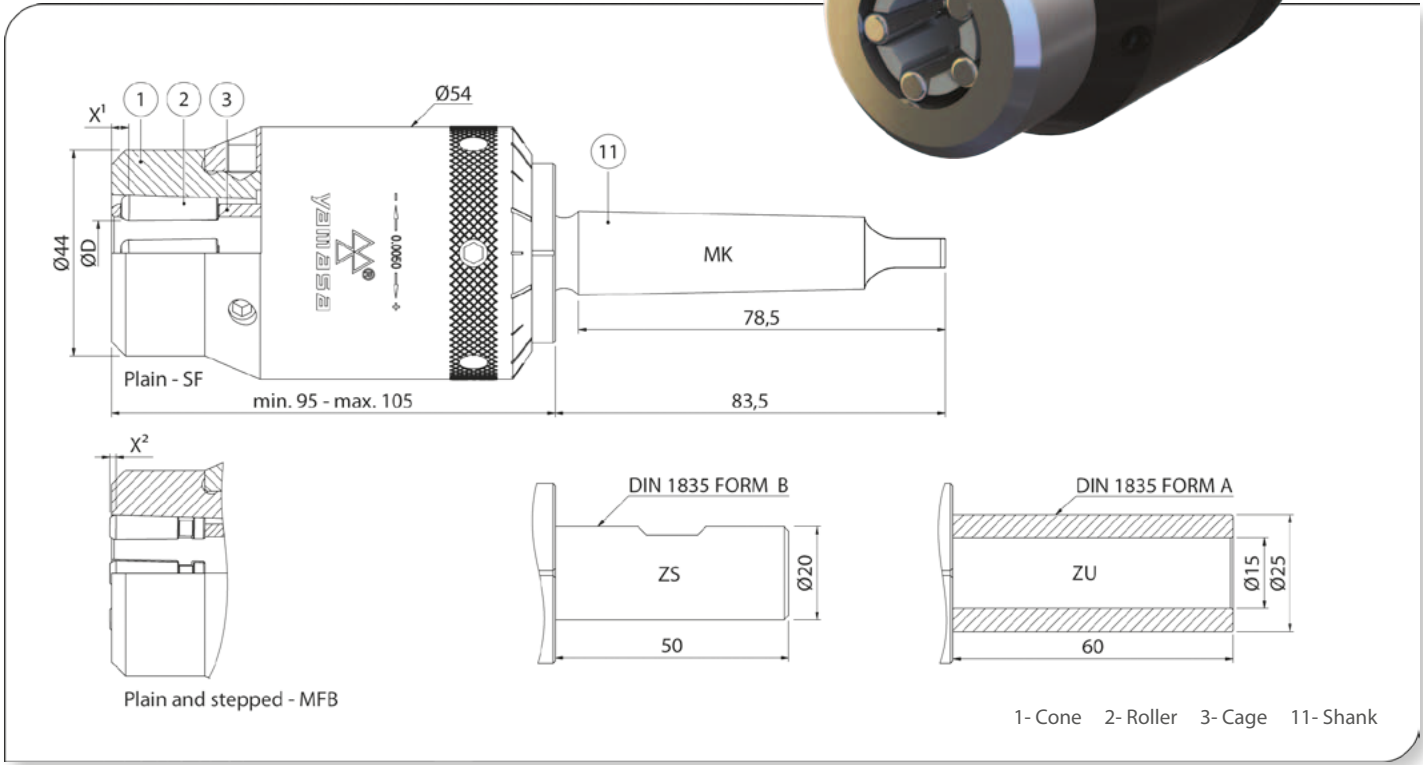

1- Cone 2- Roller 3- Cage 11- Shank

Recommended machining parameters

Diameter range (mm)	Revolution (rev/min)	Feed rate (mm/rev)	Feeding (mm/min)	Rotation direc.	Rolling share	Pre-machining roughness	Pre-machining	Coolant
				Retreat	Tool preload			
01,00 - 08,00	1000	0,45	450	CCW (M3) ----- Rapidly (G0)	up to 0,015 mm	Rz = 5 - 15 μm	Lathe or grinding	Oil or emulsion
09,00 - 11,00	1000	0,60	600					
12,00 - 14,00	1000	0,75	750					

Product selection

MX Tool selection (complete)									Spare part selection								
Tool body	Dia. \varnothing -mm	Version		Rolling length		Shank			MX Cage		MX Cone		Roller		Qua.		
		SF	MFB	MK/ZS	ZU				Dia. \varnothing -mm	Version	Dia. \varnothing -mm	Version	Code				
MX1	1,00	1	3	75	UNL	MK2	ZS20	ZU25	1,00	1	3	1,00	1	3	500102	500301	3
	2,00								2,00								
	3,00								3,00								
	4,00								4,00								
	5,00								5,00								
	6,00								6,00								
	7,00								7,00			500130			500311	4	
	8,00								8,00								
	9,00								9,00								
	10,00								10,00								
	11,00								11,00								
	12,00								12,00								
	12,00								12,00								
	14,00								14,00								

How to order | Order samples

MX1-14,00-3-75-MK2 Roller burnishing tool	14,00-3 MX Cage	14,00-3 MX Cone	500311 Roller
---	-----------------	-----------------	---------------

You can create order codes of the tool and spare parts by looking at the product selection table. For this, please rank the requested product features side by side. All dimensions in mm. **SF(1)**: Self feeding - plain shaft **MFB(3)**: Machine feeding - plain and stepped shaft

External Roller Burnishing Tools

Minimum edge

Diameter range	X ¹ / SF	X ² / MFB
015,00 - 024,00	7,7	0,8

X²: It is possible to come to near the edge more. Please ask for special situations.

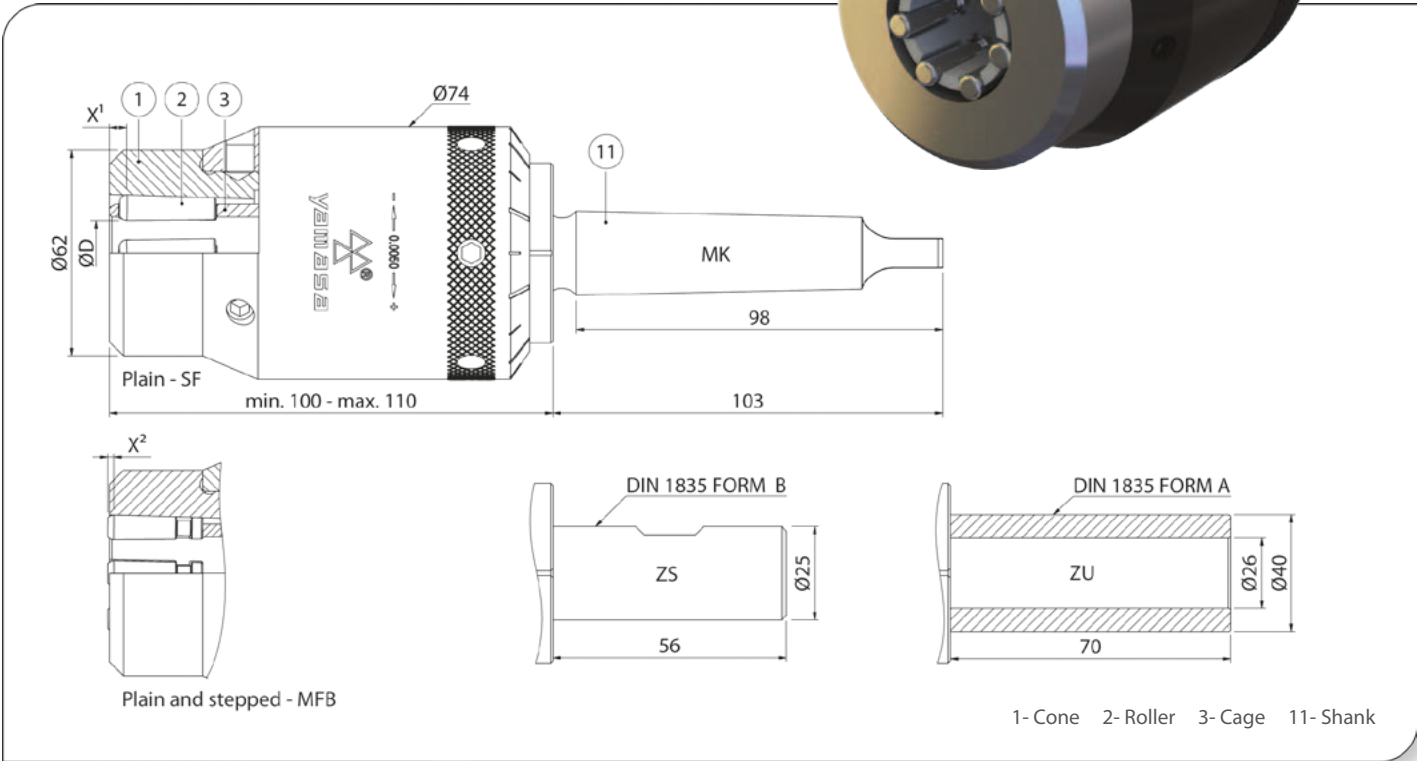

Recommended machining parameters

Diameter range (mm)	Revolution (rev/min)	Feed rate (mm/rev)	Feeding (mm/min)	Rotation direc.	Rolling share	Pre-machining roughness	Pre-machining	Coolant
				Retreat	Tool preload			
15,00 - 17,00	1000	0,75	750	CCW (M3)	up to 0,02 mm	Rz = 5 - 20 µm	Lathe or grinding	Oil or emulsion
18,00 - 21,00	1000	0,90	900					
22,00 - 24,00	1000	1,05	1050	Rapidly (G0)	up to 0,05 mm			

Product selection

MX Tool selection (complete)									Spare part selection								
Tool body	Dia. Ø-mm	Version		Rolling length		Shank			MX Cage		MX Cone		Roller		Qua.		
		SF	MFB	MK/ZS	ZU				Dia. Ø-mm	Version	Dia. Ø-mm	Version	Code				
MX2	15,00	1	3	75	UNL	MK3	ZS25	ZU40	15,00	1	3	15,00	1	3	500130	500311	5
	16,00								16,00								
	17,00								17,00								
	18,00								18,00								
	19,00								19,00								
	20,00								20,00								
	21,00								21,00								
	22,00								22,00								
	23,00								23,00								
	24,00								24,00								

How to order | Order samples

MX2-15,00-1-UNL-ZU40 Roller burnishing tool	15,00-1 MX Cage	15,00-1 MX Cone	500130 Roller
---	-----------------	-----------------	---------------

You can create order codes of the tool and spare parts by looking at the product selection table. For this, please rank the requested product features side by side. All dimensions in mm. **SF(1):** Self feeding - plain shaft **MFB(3):** Machine feeding - plain and stepped shaft

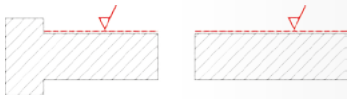

✓ Achievable surface roughness $Rz < 1 \mu\text{m} / Ra < 0,16 \mu\text{m}$

MX Type | Between $\varnothing 25 - 49 \text{ mm}$

External Roller Burnishing Tools

Minimum edge

Diameter range	X ¹ / SF	X ² / MFB
025,00 - 049,00	8,8	0,8

X²: It is possible to come to near the edge more. Please ask for special situations.

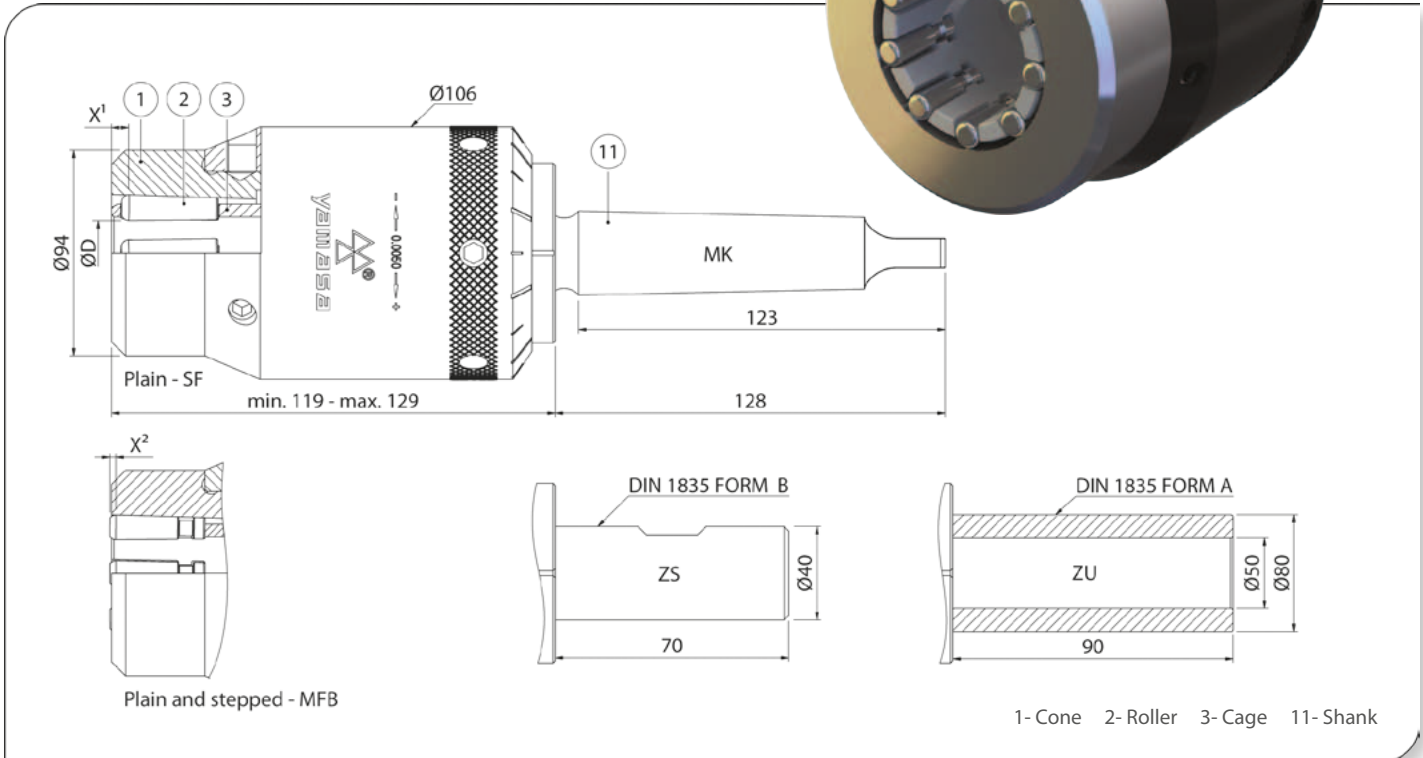

1- Cone 2- Roller 3- Cage 11- Shank

Recommended machining parameters

Diameter range (mm)	Revolution (rev/min)	Feed rate (mm/rev)	Feeding (mm/min)	Rotation direc.	Rolling share	Pre-machining roughness	Pre-machining	Coolant
				Retreat	Tool preload			
25,00 - 31,00	1000	1,05	1050	CCW (M3)	up to 0,02 mm	Rz = 5 - 20 μm	Lathe or grinding	Oil or emulsion
32,00 - 38,00	840	1,05	880	-----	-----			
39,00 - 49,00	650	1,35	870	Rapidly (G0)	up to 0,06 mm			

Product selection

MX Tool selection (complete)										Spare part selection								
Tool body	Dia. \varnothing -mm	Version		Rolling length		Shank			MX Cage		MX Cone		Roller		Qua.			
		SF	MFB	MK/ZS	ZU				Dia. \varnothing -mm	Version	Dia. \varnothing -mm	Version	Code					
MX3	25,00	1	3	100	UNL	MK4	ZS40	ZU80	25,00	1	3	25,00	1	3	500128	500307	7	
	26,00								26,00									
	27,00								27,00									
	28,00								28,00									
	29,00								29,00									
	30,00								30,00									
	32,00								32,00									
	34,00								34,00									
	36,00								36,00									
	38,00								38,00									
	39,00								39,00									
	45,00								45,00									
	49,00								49,00									

How to order | Order samples

MX3-25,00-3-100-ZS40 Roller burnishing tool	25,00-3 MX Cage	25,00-3 MX Cone	500307 Roller
---	-----------------	-----------------	---------------

You can create order codes of the tool and spare parts by looking at the product selection table. For this, please rank the requested product features side by side. All dimensions in mm. **SF(1)**: Self feeding - plain shaft **MFB(3)**: Machine feeding - plain and stepped shaft

External Roller Burnishing Tools

Minimum edge

Diameter range	X ¹ / SF	X ² / MFB
050,00 - 085,00	9,3	0,8

X²: It is possible to come to near the edge more. Please ask for special situations.

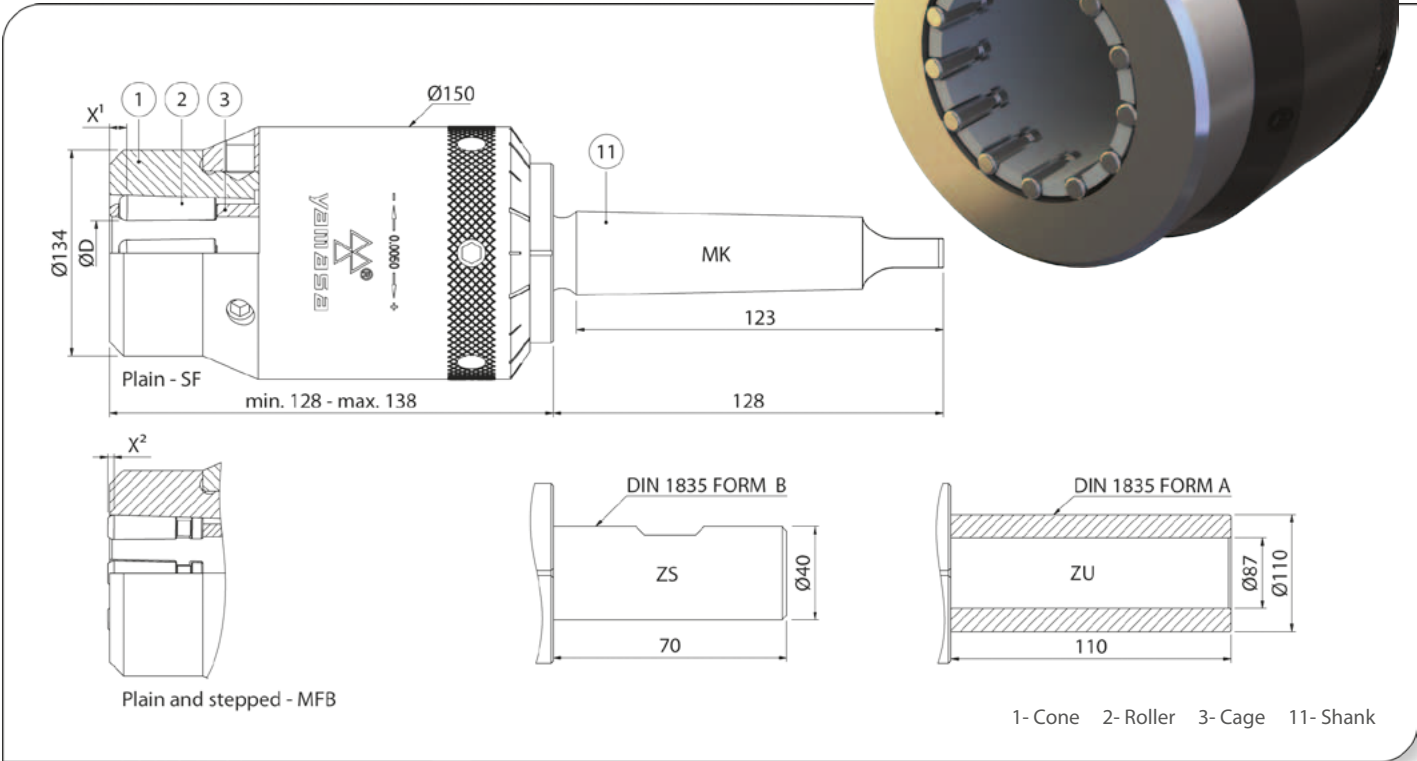
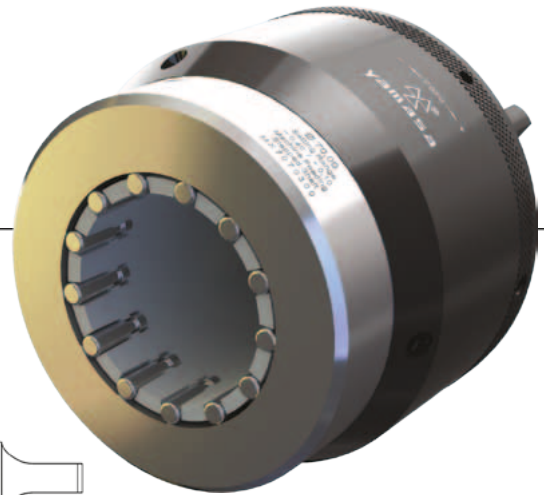

Recommended machining parameters

Diameter range (mm)	Revolution (rev/min)	Feed rate (mm/rev)	Feeding (mm/min)	Rotation direc.	Rolling share	Pre-machining roughness	Pre-machining	Coolant
				Retreat	Tool preload			
50,00 - 51,00	620	1,35	830	CCW (M3)	up to 0,02 mm	Rz = 5 - 20 µm	Lathe or grinding	Oil or emulsion
52,00 - 69,00	460	1,65	760		Rapidly (G0)			
70,00 - 85,00	370	1,95	720					

Product selection

MX Tool selection (complete)									Spare part selection								
Tool body	Dia. Ø-mm	Version		Rolling length		Shank			MX Cage		MX Cone		Roller		Qua.		
		SF	MFB	MK/ZS	ZU				Dia. Ø-mm	Version SF MFB	Dia. Ø-mm	Version SF MFB	Code SF MFB				
MX4	50,00	1	3	100	UNL	MK4	ZS40	ZU110	50,00	1	3	50,00	1	3	500128	500307	9
	51,00								51,00								
	52,00								52,00								
	54,00								54,00								
	56,00								56,00								
	58,00								58,00								
	60,00								60,00								
	65,00								65,00								
	69,00								69,00								
	70,00								70,00								
	75,00								75,00								
	80,00								80,00								
	85,00								85,00								

How to order | Order samples

MX4-50,00-3-100-ZS40 Roller burnishing tool	50,00-3 MX Cage	50,00-3 MX Cone	500307 Roller
---	-----------------	-----------------	---------------

You can create order codes of the tool and spare parts by looking at the product selection table. For this, please rank the requested product features side by side. All dimensions in mm. **SF(1):** Self feeding - plain shaft **MFB(3):** Machine feeding - plain and stepped shaft

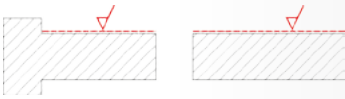

✓ Achievable surface roughness $Rz < 1\mu\text{m} / Ra < 0,16\mu\text{m}$

MX Type | Between $\varnothing 86 - 110\text{ mm}$

External Roller Burnishing Tools

Minimum edge

Diameter range	X ¹ / SF	X ² / MFB
086,00 - 110,00	12,9	1,6

X²: It is possible to come to near the edge more. Please ask for special situations.

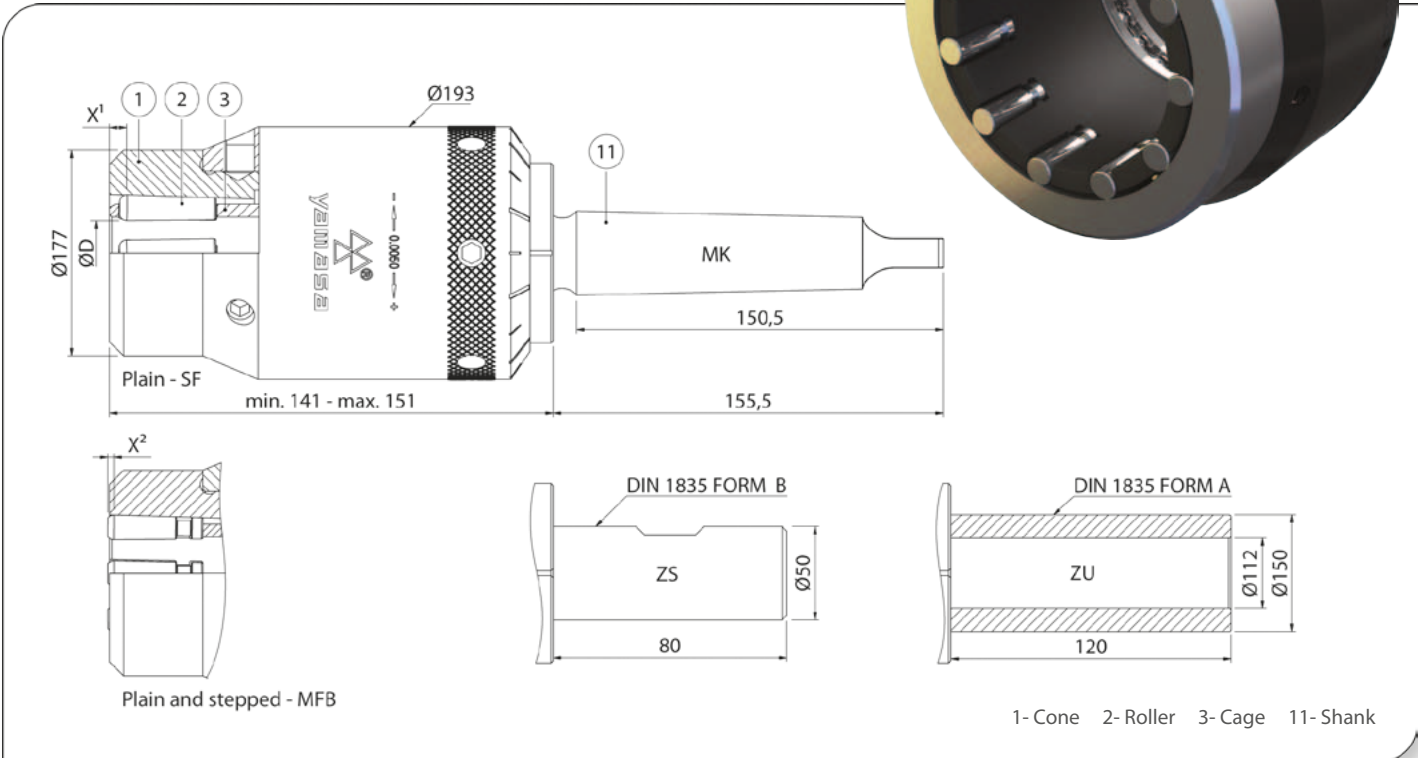
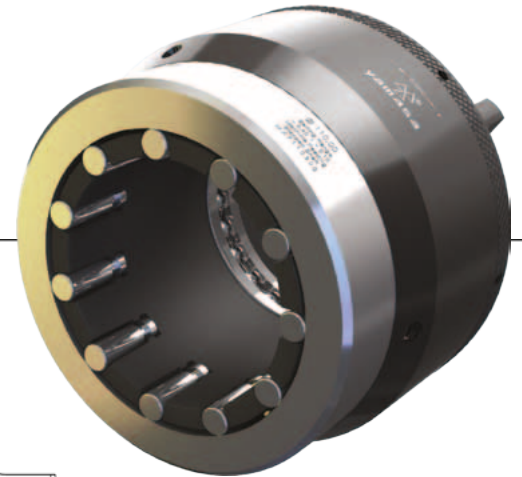

Recommended machining parameters

Diameter range (mm)	Revolution (rev/min)	Feed rate (mm/rev)	Feeding (mm/min)	Rotation direc.	Rolling share	Pre-machining roughness	Pre-machining	Coolant
				Retreat	Tool preload			
086,00 - 095,00	330	1,35	440	CCW (M3)	up to 0,03 mm	Rz = 5 - 30 μm	Lathe or grinding	Oil or emulsion
096,00 - 110,00	290	1,65	480	Rapidly (G0)	up to 0,08 mm			

Product selection

MX Tool selection (complete)										Spare part selection							
Tool body	Dia. \varnothing -mm	Version		Rolling length		Shank			MX Cage		MX Cone		Roller		Qua.		
		SF	MFB	MK/ZS	ZU				Dia. \varnothing -mm	Version	Dia. \varnothing -mm	Version	Code				
MX5	086,00	1	3	115	UNL	MK5	ZS50	ZU150	086,00	1	3	086,00	1	3	500132	500306	9
	088,00								088,00								
	090,00								090,00								
	092,00								092,00								
	095,00								095,00								
	096,00								096,00								
	098,00								098,00								
	100,00								100,00								
	102,00								102,00								
	104,00								104,00								
	106,00								106,00								
	108,00								108,00								
	110,00								110,00								

How to order | Order samples

MX5-86,00-3-115-ZS50 Roller burnishing tool	86,00-3 MX Cage	86,00-3 MX Cone	500306 Roller
---	-----------------	-----------------	---------------

You can create order codes of the tool and spare parts by looking at the product selection table. For this, please rank the requested product features side by side. All dimensions in mm. **SF(1)**: Self feeding - plain shaft **MFB(3)**: Machine feeding - plain and stepped shaft

External Roller Burnishing Tools

Minimum edge

Diameter range	X ¹ / SF	X ² / MFB
111,00 - 160,00	12,9	1,6

X²: It is possible to come to near the edge more. Please ask for special situations.

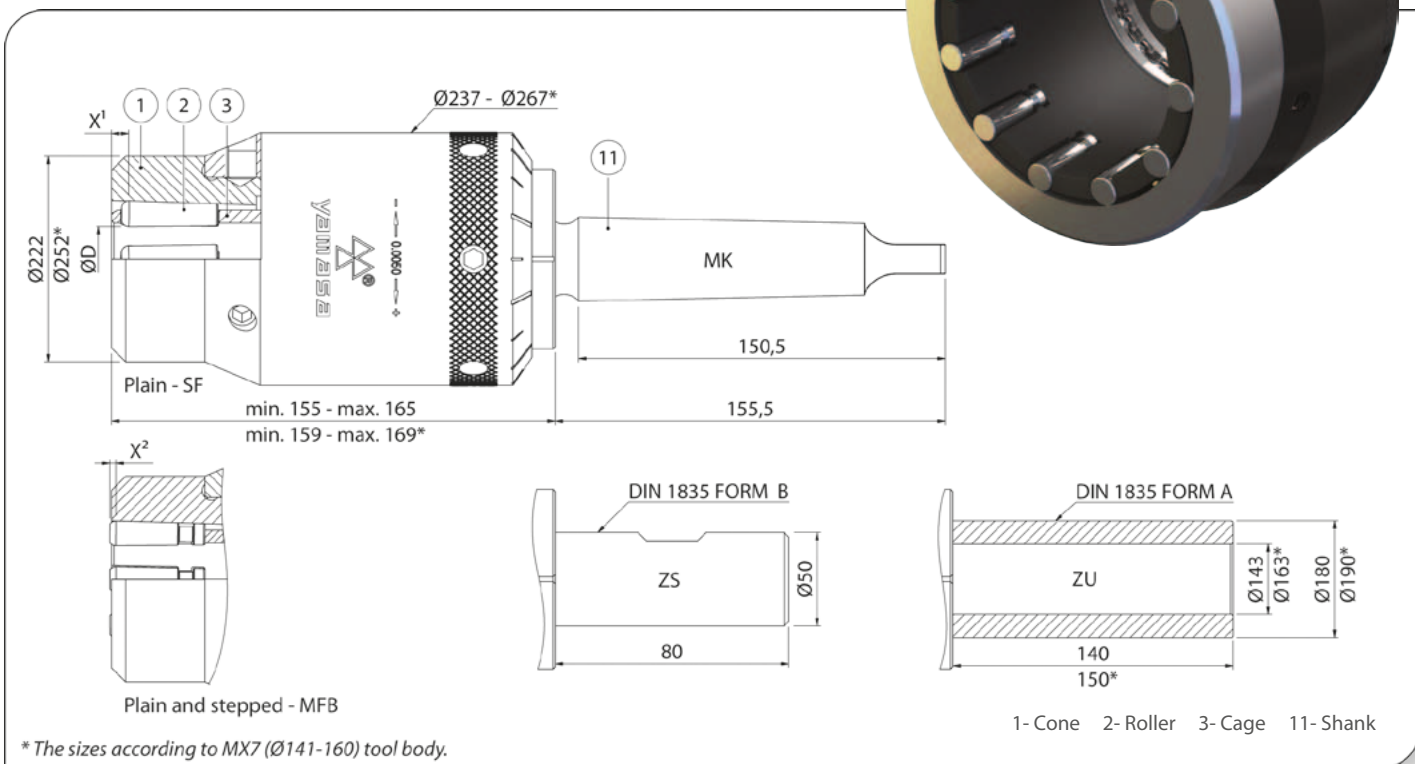
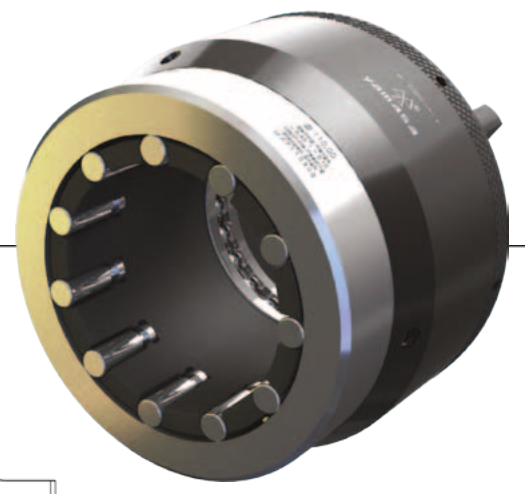

*The sizes according to MX7 (Ø141-160) tool body.

Recommended machining parameters

Diameter range (mm)	Revolution (rev/min)	Feed rate (mm/rev)	Feeding (mm/min)	Rotation direc.	Rolling share	Pre-machining roughness	Pre-machining	Coolant
				Retreat	Tool preload			
111,00 - 120,00	270	1,65	445	CCW (M3)	up to 0,03 mm	Rz = 5 - 30 µm	Reaming or lathe	Oil or emulsion
121,00 - 140,00	230	1,95	448					
141,00 - 160,00	200	1,95	390	Rapidly (G0)	up to 0,08 mm			

Product selection

MX Tool selection (complete)								Spare part selection									
Tool body	Dia. Ø-mm	Version		Rolling length		Shank			MX Cage		MX Cone		Roller		Qua.		
		SF	MFB	MK/ZS	ZU				Dia. Ø-mm	Version	Dia. Ø-mm	Version	Code				
MX6	111,00	1	3	130	UNL	MK5	ZS50	ZU180	111,00	1	3	111,00	1	3	500132	500306	11
	120,00								120,00								
	121,00								121,00								
	140,00			140,00													
	141,00			141,00													
	160,00			160,00													
MX7	141,00	1	3	135	UNL	MK5	ZS50	ZU190	141,00	1	3	141,00	1	3	500132	500306	13
	160,00								160,00								

How to order | Order samples

MX6-140,00-1-UNL-ZU180 Roller burnishing tool	140,00-1 MX Cage	140,00-1 MX Cone	500132 Roller
---	------------------	------------------	---------------

You can create order codes of the tool and spare parts by looking at the product selection table. For this, please rank the requested product features side by side. All dimensions in mm. **SF(1)**: Self feeding - plain shaft **MFB(3)**: Machine feeding - plain and stepped shaft

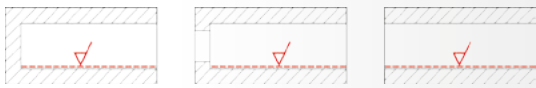

✓ Achievable surface roughness Rz < 1 μm / Ra < 0,16 μm

COMPACT DESIGN

For swiss and multi-spindle automatic type machines.

Circumferential speed: max. 250 m/min.
 Feed rate: 0,05 - 0,3 mm/rev. per roller
 Machinable hardness: max. 42 - 45 HRC
 Adjustment precision: 0,0025 mm



Rolling length	Tool length (b)	e
30 (25*)	50	32
50 (45*)	70	52

*rolling length for through hole tool

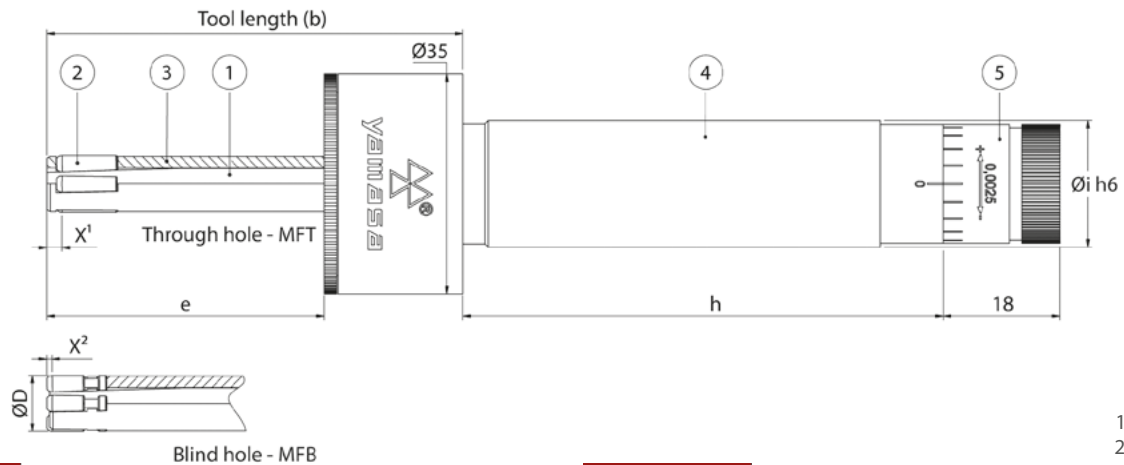

Minimum edge

Diameter range	X ¹ / MFT	X ² / MFB
05,00	2,4	-
06,00 - 14,00	2,6	0,8

X²: It is possible to come to near the edge more. Please ask for special situations.

Setting range

Diameter range	MFT	MFB
05,00	-0,05 / +0,10	-
06,00 - 08,00	-0,05 / +0,20	-0,05 / +0,20
09,00 - 14,00	-0,10 / +0,40	-0,05 / +0,40

- 1- Cone
- 2- Roller
- 3- Cage
- 4- Shank
- 5- Adjusting housing

Recommended machining parameters

Diameter range (mm)	Revolution (rev/min)	Feed rate (mm/rev)	Feeding (mm/min)	Rotation direc.	Rolling share	Pre-machining roughness	Pre-machining	Coolant
				Retreat	Tool preload			
05,00	1000	0,30	300	CCW (M3) Rapidly (G0)	up to 0,02 mm	Rz = 5 - 15 μm	Reaming or lathe	Oil or emulsion
06,00 - 07,00	1000	0,45	450		up to 0,05 mm			
08,00 - 14,00	1000	0,60	600		up to 0,05 mm			

Product selection

MDX Tool selection (complete)							Spare part selection													
Tool type	Dia. Ø-mm	Version		Rolling length		Cyl. shank ZA(Øixh)	MDX Cage				MDX Cone				Roller		Qua.			
		MFT	MFB	MFT	MFB		Dia. Ø-mm	Version	Rolling length		Dia. Ø-mm	Version	Rolling length		Code					
MDX	5,00	2	3	25 45	30 50	ZA19,05x76	5,00	2	3	25 45	30 50	5,00	2	3	25 45	30 50	500115	-	3	
	6,00					ZA19,05x115	6,00					6,00					500100	500308		
	7,00					ZA20x76	7,00					7,00								
	8,00					ZA20x115	8,00					8,00							4	
	9,00					ZA22x76	9,00					9,00					50108	500300		
	10,00					ZA22x115	10,00					10,00								
	11,00					ZA25x76	11,00					11,00								
	12,00					ZA25x115	12,00					12,00								
	13,00					ZA25,40x76	13,00					13,00							500102	500301
	14,00					ZA25,40x115	14,00					14,00								

How to order | Order samples

MDX-6,00-3-30-ZA20x76 Roller Burnishing Tool	6,00-3-30 MDX Cage	6,00-3-30 MDX Cone	500308 Roller
--	--------------------	--------------------	---------------

You can create order codes of the tool and spare parts by looking at the product selection table. For this, please rank the requested product features side by side. All dimensions in mm. **MFT(2)**: Machine feeding - through hole **MFB(3)**: Machine feeding - blind hole

External Micro Burnishing Tools

COMPACT DESIGN - internal coolant
For swiss and multi-spindle automatic type machines.

Circumferential speed: max.250 m/min.
 Feed rate: 0,05 - 0,3 mm/rev. per roller
 Machinable hardness: max. 42 - 45 HRC
 Adjustment precision: 0,0025 mm

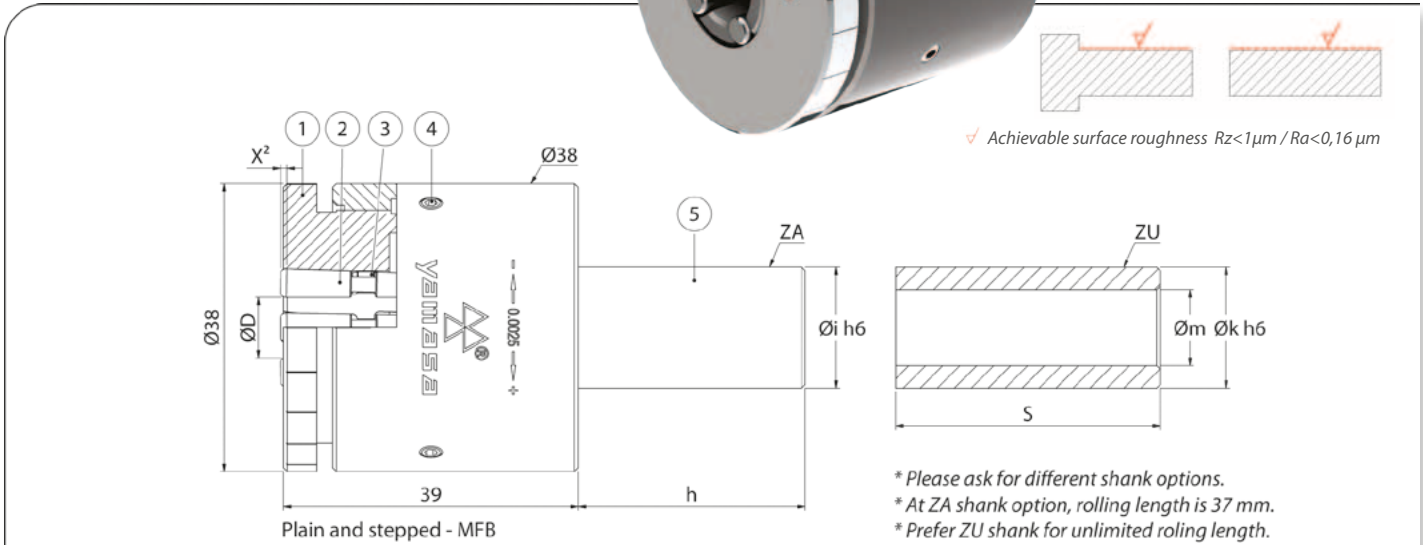

Minimum edge

Diameter range	X ² / MFB
01,00 - 14,00	0,8

X²: It is possible to come to near the edge more. Please ask for special situations.

Setting range

Diameter range	MFB
01,00 - 014,00	-0,10 / +0,05

- 1- Cone
- 2- Roller
- 3- Cage
- 4- Screw
- 5- Shank

Recommended machining parameters

Diameter range (mm)	Revolution (rev/min)	Feed rate (mm/rev)	Feeding (mm/min)	Rotation direc.	Rolling share	Pre-machining roughness	Pre-machining	Coolant
				Retreat	Tool preload			
01,00 - 05,00	1000	0,45	450	CCW (M3)	up to 0,015 mm	Rz = 5 - 15 µm	Lathe or grinding	Oil or emulsion
06,00 - 08,00	1000	0,60	600					
09,00 - 14,00	1000	0,75	750	Rapidly (G0)	up to 0,04 mm			

Product selection

MXS Tool selection (complete)						Spare part selection						
Tool body	Dia. Ø-mm	Version MFB	Rolling length		Cylindrical shank*		MXS Cage		MXS Cone		Roller	
			ZA- int.coolant	ZU	ZA(Øixh)	ZU(ØkxSxØm)	Dia. Ø-mm	Version MFB	Dia. Ø-mm	Version MFB	Code MFB	Qua.
MXS1	1,00	3	37	UNL (Unlimited)	ZA12x40 • ZA16x40 • ZA19,05x40 • ZA20x40 • ZA22x40 • ZA25x40 • ZA25,40x40	ZU19,05x76x12 • ZU19,05x115x12 • ZU20x76x12 • ZU20x115x12 • ZU22x76x12 • ZU22x115x12 • ZU25x76x15 • ZU25x115x15 • ZU25,40x76x15 • ZU25,40x115x15	1,00	3	1,00	3	500301	3
	2,00						2,00					
	3,00						3,00					
	4,00						4,00					
	5,00						5,00					
	6,00						6,00					
	7,00						7,00					
	8,00						8,00					
	9,00						9,00					
	10,00						10,00					
	11,00						11,00					
	14,00						14,00					

UNL at ZU25 or 25,4 shank. Other ZU shanks 37 mm.

How to order | Order samples

MXS1-2,00-3-37-ZA20x40 Roller burnishing tool	2,00-3 MXS Cage	2,00-3 MXS Cone	500301 Roller
---	-----------------	-----------------	---------------

You can create order codes of the tool and spare parts by looking at the product selection table. For this, please rank the requested product features side by side. All dimensions in mm. **MFB(3)**: Machine feeding - plain and stepped shaft

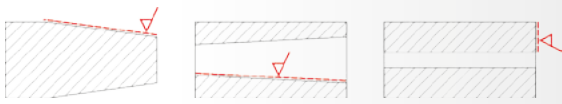

✓ Achievable surface roughness $Rz < 1 \mu m$ / $Ra < 0,16 \mu m$

Explanation

Taper-Flat Surface Burnishing Tools

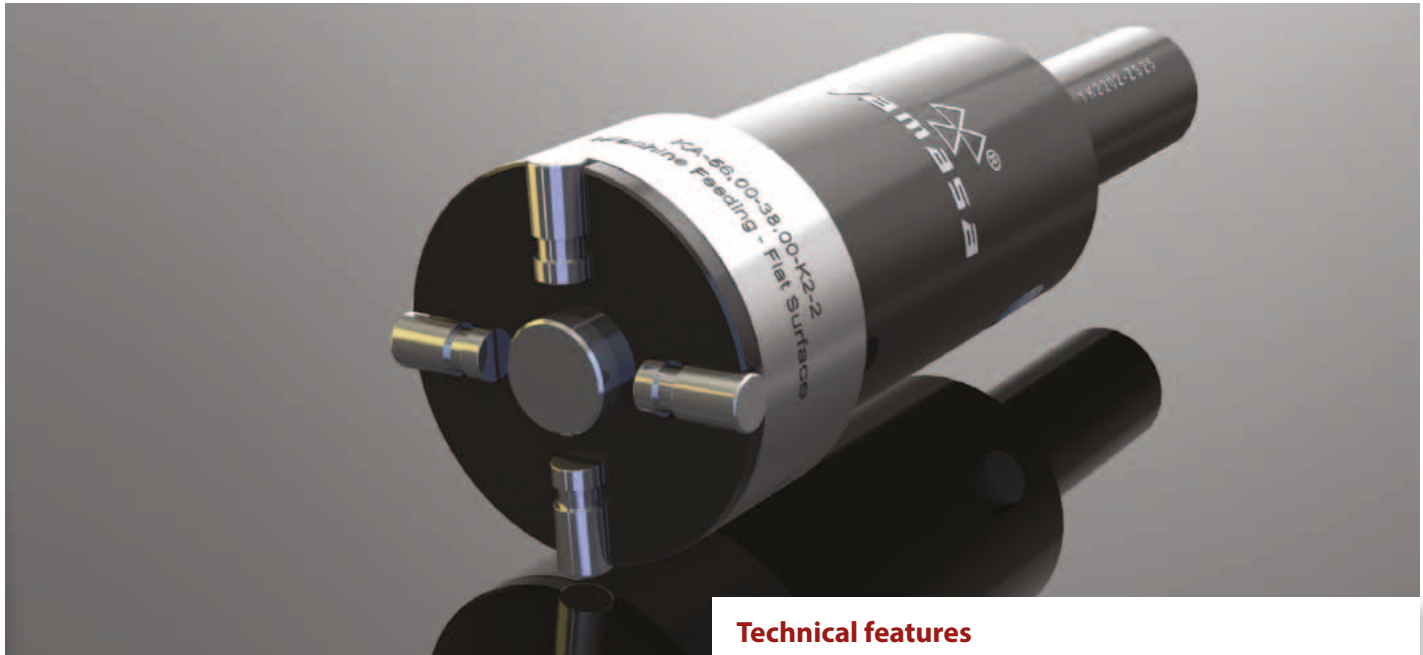

COMPACT DESIGN
For swiss and multi-spindle automatic type machines.



MKI Micro roller burnishing tool

Technical features

These tools are used to process the interior-outer conics and flat surfaces. They are suitable to roller burnish for all workpieces requiring precision. The tool body is equipped with a special spring system. This spring system enables the pressure, which is applied on the workpiece, adjusted specifically. At the same time, this spring system provides the tool a safety stroke (safety distance). The safety stroke prevents overload on the workpiece and the machine. Furthermore it helps to get a standard and perfect surface quality. The spring system which is designed specially for each tool, gives the opportunity to apply the same pressure everytime to the workpiece which is processed, thus a precision and standard size is obtained.

Any adjustment mechanism is not mentioned in tools. The roller burnishing process occurs when the roller head, which is prepared specially due to the sizes of workpiece, is contacted to the workpiece with a certain force. During the process either the tool or the workpiece may turn. These tools are capable to process all kinds of metallic materials with 1400 N/mm² tensile strength and hardness up to max. 42-45 HRC. Tools work by universal or CNC lathes, machining centers, drilling machines, milling machines or other machines which process by turning.

Machining parameters

Circumferential speed	max.40 m/min.
Feed rate	0,1 - 0,3 mm/rev.
Rolling share	up to 0,01 mm
Machinable material hardness	max. 42 - 45 HRC
Pre-machining roughness	$Rz = 5 - 20 \mu m$
Pre-machining	lathe or reaming
Coolant	Oil or emulsion



Tapered internal surface
KI type



Tapered external surface
KD type



Flat surface
KA type

Taper-Flat Surface Burnishing Tools

Tool structure

K Series tools consist of a body and a roller head. The tool body consists of a shank and a precision housing equipped with the pressurized spring system. The special spring system is designed due to the requirements of the work suitability. The tool is sending with Morse taper or cylindrical shank due to the preference. The roller head consists of cage, cone and rollers. These parts are designed and produced due to the dimensions of the workpiece. Later the roller heads are assembled to the proper body. As the roller heads are designed upon the specifications of the desired work, it is not possible to keep these parts in stock.

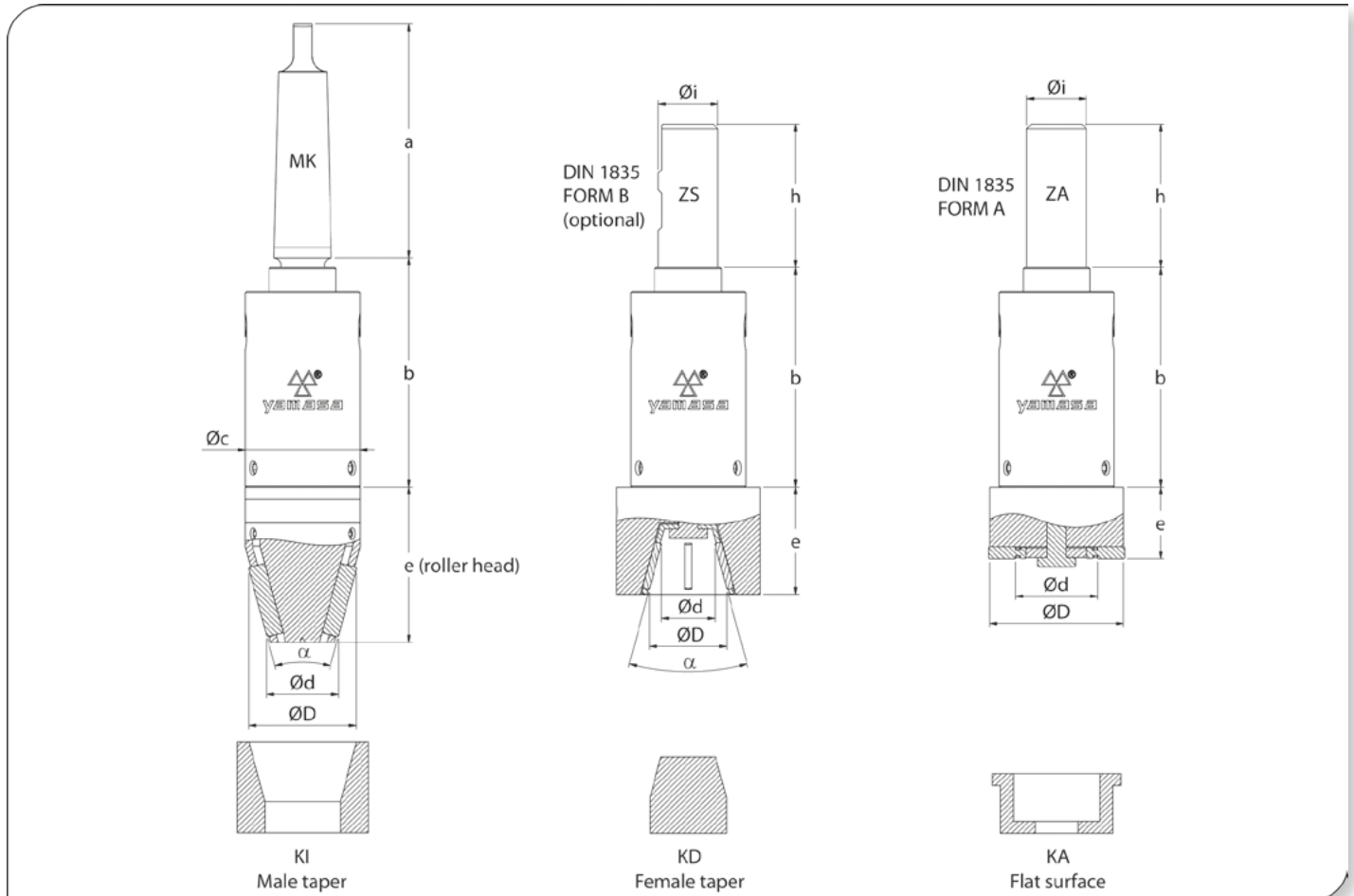

Product selection

K Series tool selection (complete)							Dimensions						
Tool type			Diameter ØD	Diameter Ød	Angle* α	Shank	Tool body	Shank		a	b	c	e (roller head)
								Cylindrical (Øi x h)	MK				
KI	KD	KA	x,xx	x,xx	x°	MK · ZS · ZA	K1	Ø20h6 X 50	MK2	78,5	62	33	it can be changed according to the workpiece and surface dimensions.
							K2	Ø25h6 X 56	MK3	98	85	48	
							K3	Ø32h6 X 60	MK4	123	93	65	

* Only for KI and KD tools. All dimensions in mm.

How to order | Order samples

KI-35,00-15,00-30°-ZA Roller Burnishing Tool

You can create order codes of the tool by looking at the product selection table. For this, please rank the requested product features side by side.

Tool body selection is made by YAMASA according to material features and sizes of workpiece. Roller heads are designed according to workpiece sizes.

It is enough to send us order code of your selected product together with following informations. After that we will inform you the suitable tool configuration for your work.

Needed informations for tool configuration

- Material:
- Material hardness (HRC etc.):
- Material yield strength (N/mm²):
- Workpiece technical drawing

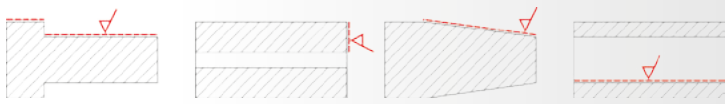

✓ Achievable surface roughness $Rz < 1 \mu\text{m} / Ra < 0,16 \mu\text{m}$

Cylindrical external surfaces, flat surfaces, tapers and holes

Application

YAMASA SX type tools are used for the aim of burnishing the stepped-plain shafts, tapers, flat surfaces and holes. The tools provide as well as surface hardness and at low rate calibration (measurement accuracy) beside of burnishing. The tools provide time saving through a high processing power and speed and this is a motive to prefer for the serial production.

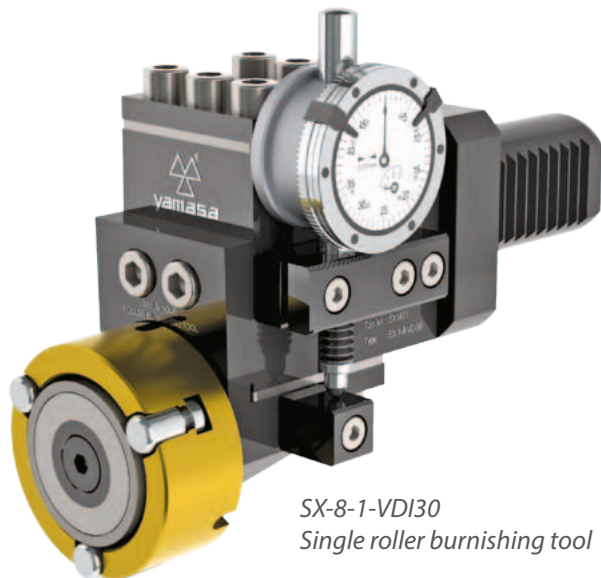

SX-8-1-VDI30
Single roller burnishing tool

Technical features and advantages

- Burnishing different sizes with same tool.
- Used on CNC and universal lathe machines.
- Tool design allows either right or left hand operation.
- Don't require settings and when the tool is fixed to the machine, it is ready to use.
- Roller burnishing force is adjustable, so it is possible to achieve high quality and standard roughness values.
- Special design and spring system apply rolling force consistently. So it provides high quality and standard work flow.
- Burnishing all kinds of metallic materials up to the tensile strength of 1400N/mm^2 and to the hardness 42-45 HRC.
- Easy to change the spare part.
- Process time is short.
- Needs min. lubrication (oil or emulsion).
- It does not make sawdust.

Hole machining

Tool type	min. diameter (mm)	Hole dept (mm)
SX5	Ø51	≤ 20
	Ø104	> 20
SX8	Ø53	≤ 20
	Ø106	> 20

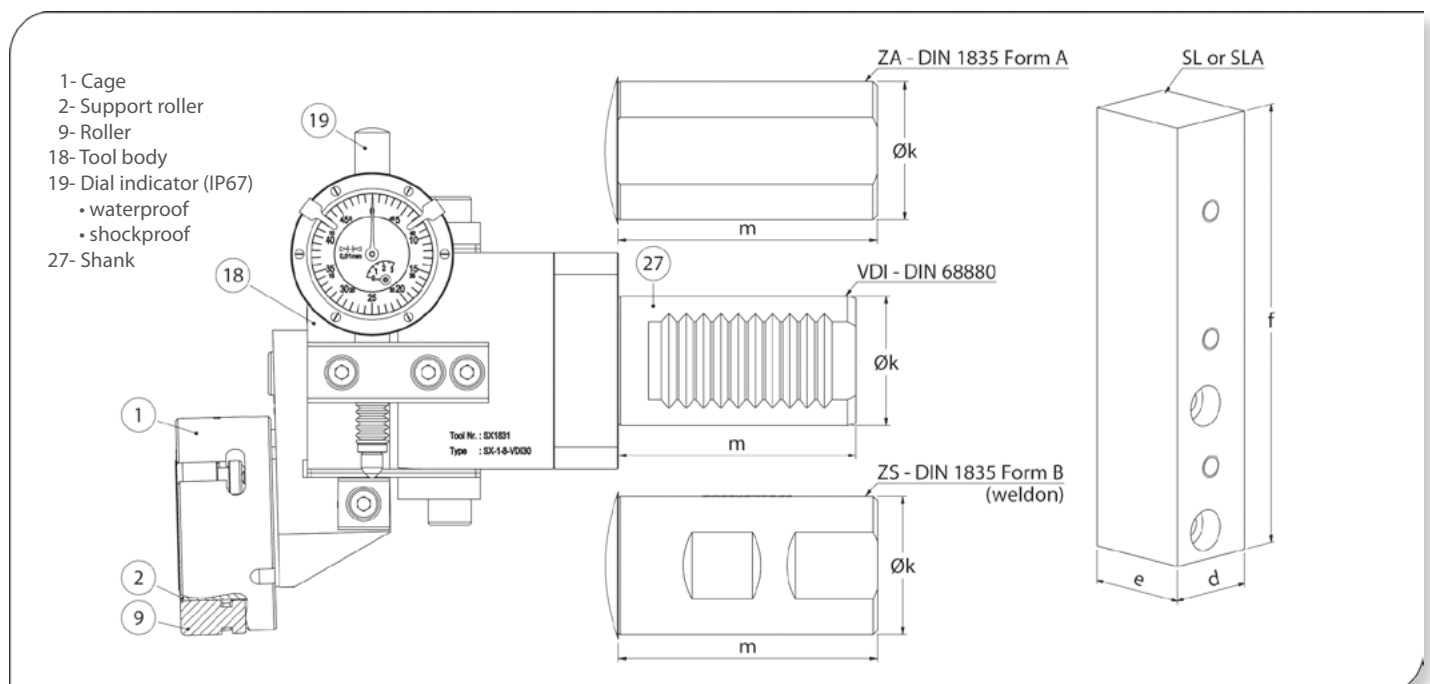

Tool structure

- Tools consist of a connecting shank, precision body, roller head and a dial indicator which shows rolling force.
- Dial indicator is IP67 protected and has a waterproof-shockproof structure.
- Square, cylindrical or VDI shanks are available. Whole shanks are demountable.

Single Roller Burnishing Tools

SX5 - Machining parameters

Working range	$\varnothing \geq 10$ (up to $\varnothing 80$ mm)
Circumferential speed	max. 150 m/min.
Feed rate	max. 0,6 mm/rev.
Rolling share	up to 0,02 mm
Rolling force	max. 5000 Newton
Pre-machining roughness	Rz = 5 - 20 μ m
Pre-machining	lathe or grinding
Coolant	Oil or emulsion

SX8 - Machining parameters

Working range	$\varnothing > 12$ (up to $\varnothing 200$ mm)
Circumferential speed	max. 150 m/min.
Feed rate	max. 0,6 mm/rev.
Rolling share	up to 0,02 mm
Rolling force	max. 5000 Newton
Pre-machining roughness	Rz = 5 - 20 μ m
Pre-machining	lathe or grinding
Coolant	Oil or emulsion

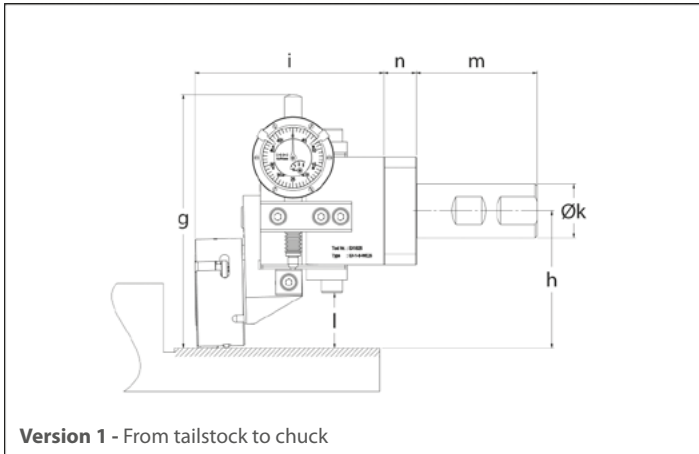

Version 1 - From tailstock to chuck

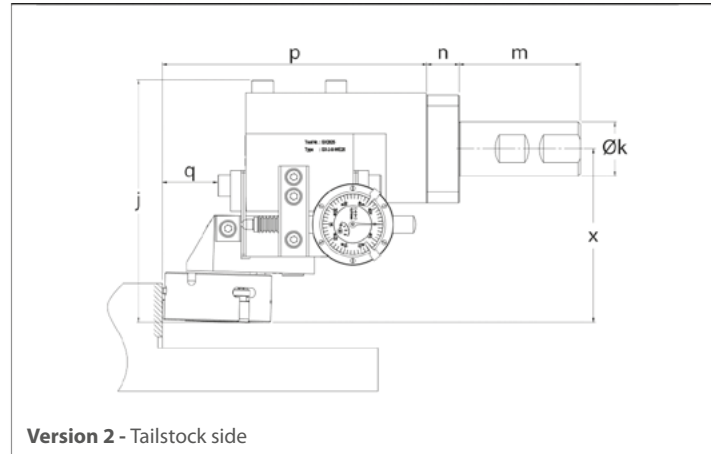

Version 2 - Tailstock side

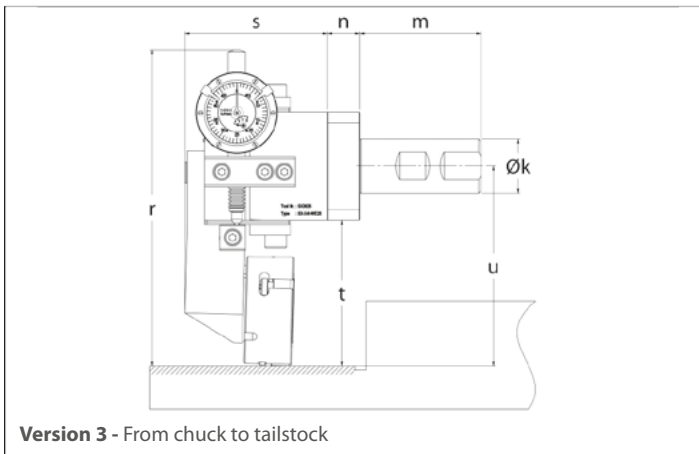

Version 3 - From chuck to tailstock

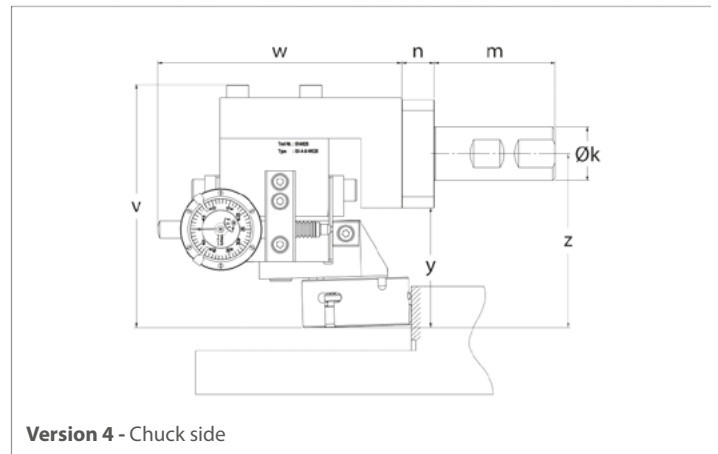

Version 4 - Chuck side

Dimensions

Tool type	Design	Height		Version 1				Version 2				Version 3				Version 4				
		a	b*	g	h	i	l	j	x	p	q	r	s	t	u	v	w	y	z	n
SX	5	43	50	115	60	88	22	113	80	120	22	144	66	64	89	113	113	55	80	15
	8			118	63	88	25	113	81	123	25	147	66	67	92	113	113	55	80	15

* b=60 mm for the tools with $\varnothing 40$ mm VDI and cylindrical shank.
There is not "n" size at square shank tools.

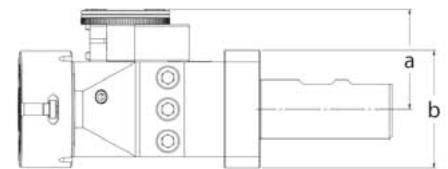

Product selection

SX Tool selection (complete)						Spare part selection								
Tool type	Design	Version	Shank			Tool type	Design	Version	SX Cage		Support roller		Roller	
			VDI	Cylindrical					Square		Tool type	Design	Tool type	Design
			DIN69880 ($\varnothing k \times m$)	DIN1835 A ($\varnothing k \times m$)	DIN1835 B ($\varnothing k \times m$)				SL (d x e x f)	SLA (d x e x f)				
SX	5 • 8	1	VDI20($\varnothing 20 \times 40$)	ZA20($\varnothing 20 \times 50$)	ZS20($\varnothing 20 \times 50$)	SL16(16x30x120)	SLA16(16x60x120)	SX	5 • 8	1 • 2 • 3 • 4	SX	5 • 8	SX	5 • 8
		2	VDI25($\varnothing 25 \times 48$)	ZA25($\varnothing 25 \times 56$)	ZS25($\varnothing 25 \times 56$)	SL20(20x30x120)	SLA20(20x60x120)							
		3	VDI30($\varnothing 30 \times 55$)	ZA32($\varnothing 32 \times 60$)	ZS32($\varnothing 32 \times 60$)	SL25(25x30x120)	SLA25(25x60x120)							
		4	VDI40($\varnothing 40 \times 63$)	ZA40($\varnothing 40 \times 70$)	ZS40($\varnothing 40 \times 70$)	SL32(32x30x120)	SLA32(32x60x120)							

All dimensions in mm.

How to order | Order samples

SX-8-1-ZS25 Single roller burnishing tool	SX-8-1 Cage	SX-8 Sup.roller	SX-8 Roller
---	-------------	-----------------	-------------

You can create order codes of the tool and spare parts by looking at the product selection table. For this, please rank the requested product features side by side.

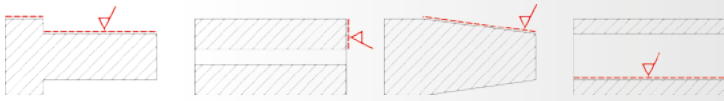

✓ Achievable surface roughness $Rz < 1 \mu\text{m}$ / $Ra < 0,16 \mu\text{m}$

Cylindrical external surfaces, flat surfaces, tapers and holes

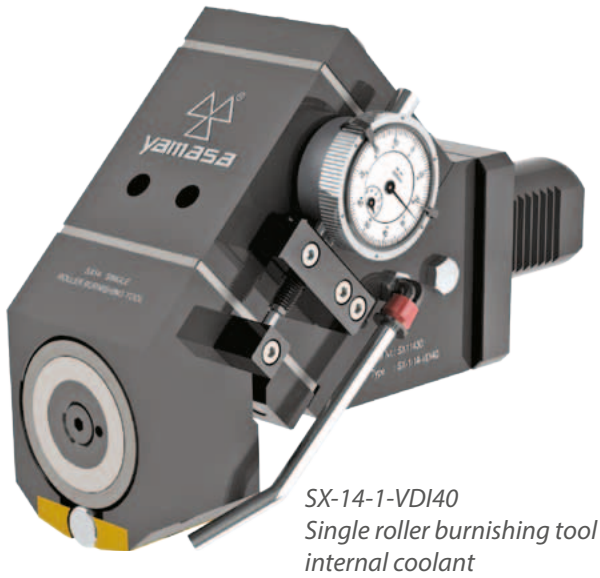

SX-14-1-VDI40
Single roller burnishing tool
internal coolant

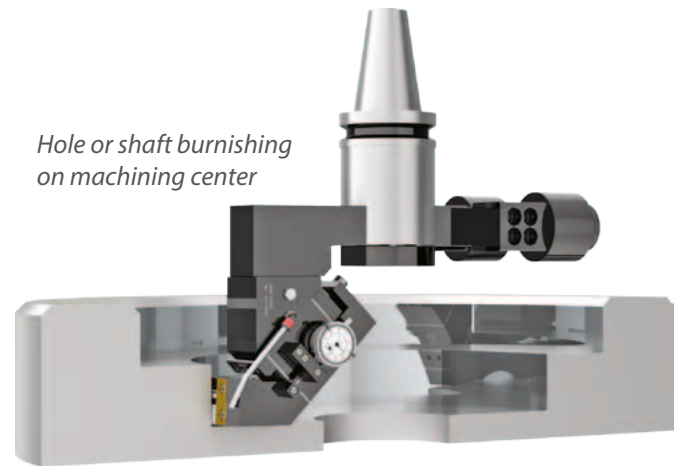

Hole or shaft burnishing
on machining center

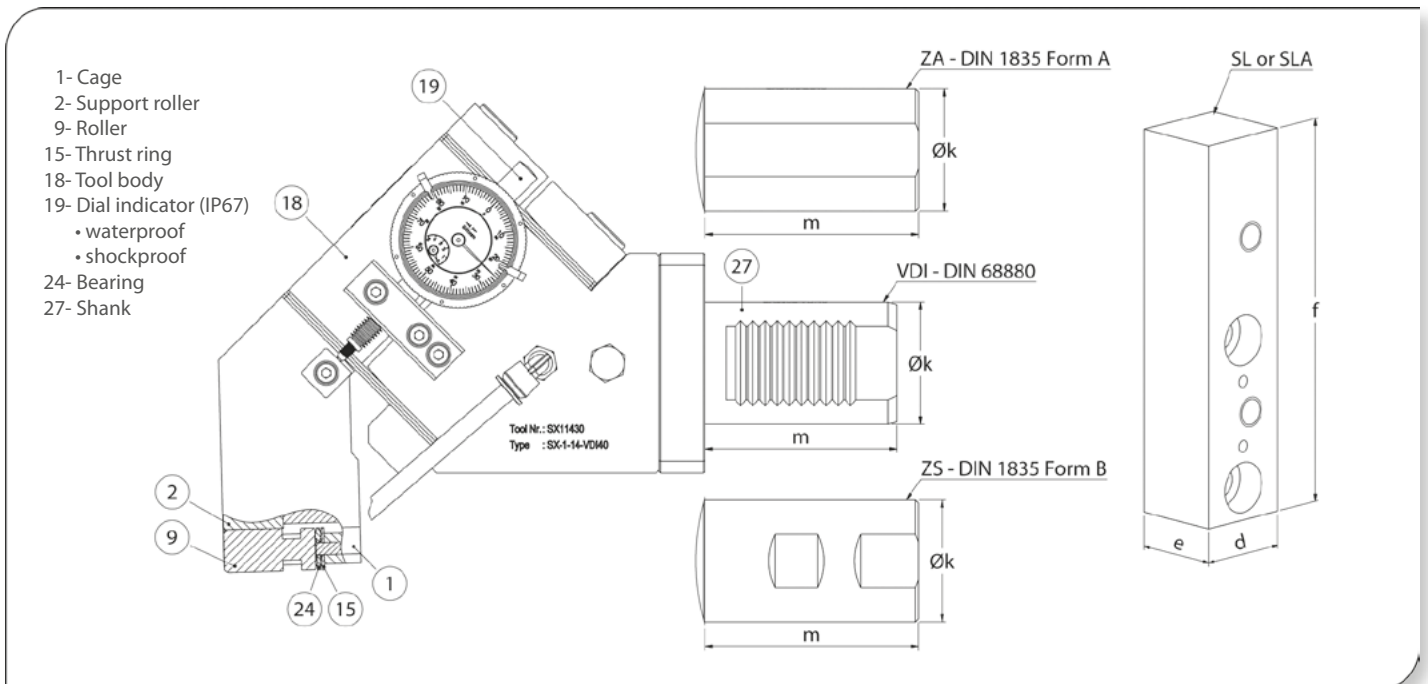

Hole machining

Tool type	min. diameter (mm)	Hole dept (mm)
SX 14	Ø110	≤ 30
	Ø151	≤ 80
	Ø160	Unlimited

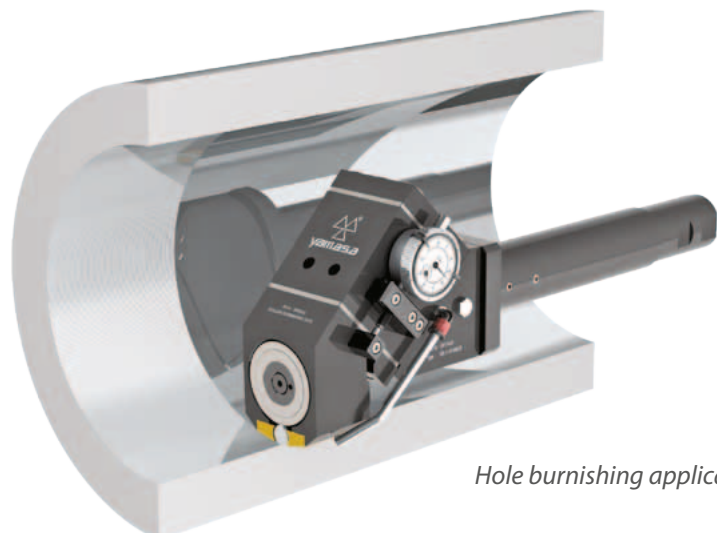

Hole burnishing application

Single Roller Burnishing Tools

SX14 - Machining parameters

Working range	$\varnothing \geq 30$ (up to $\varnothing 5000$ mm)	Rolling force	max. 10000 Newton
Circumferential speed	max. 200 m/min.	Pre-machining roughness	Rz = 5 - 20 μ m
Feed rate	max. 1 mm/rev.	Pre-machining	lathe or grinding
Rolling share	up to 0,03 mm	Coolant	Oil or emulsion

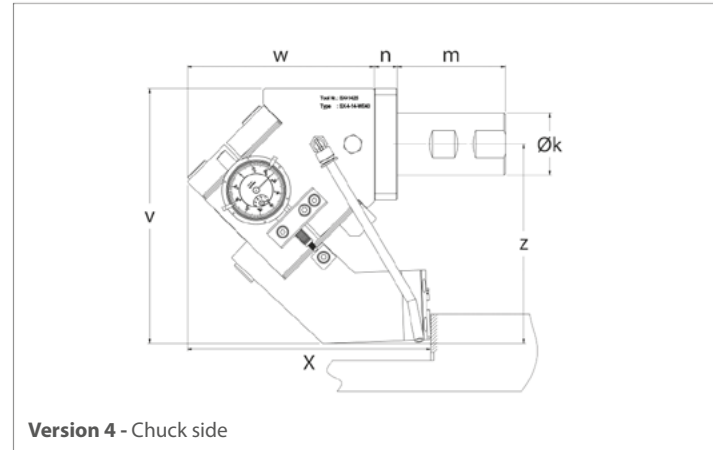
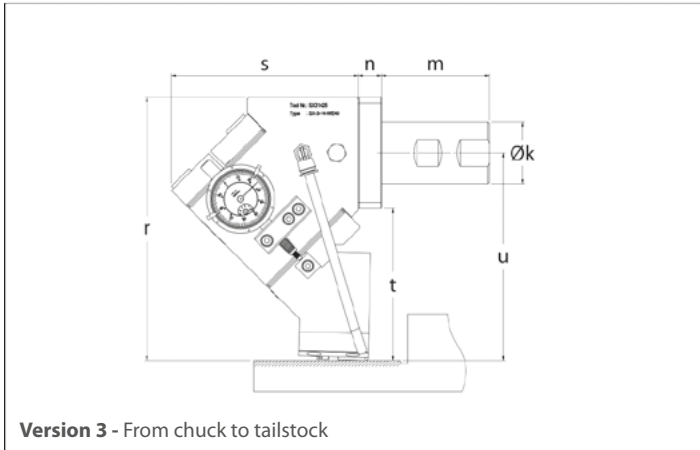
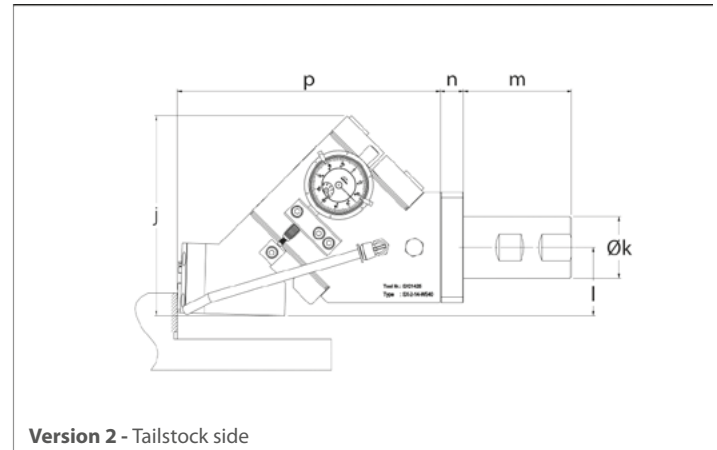
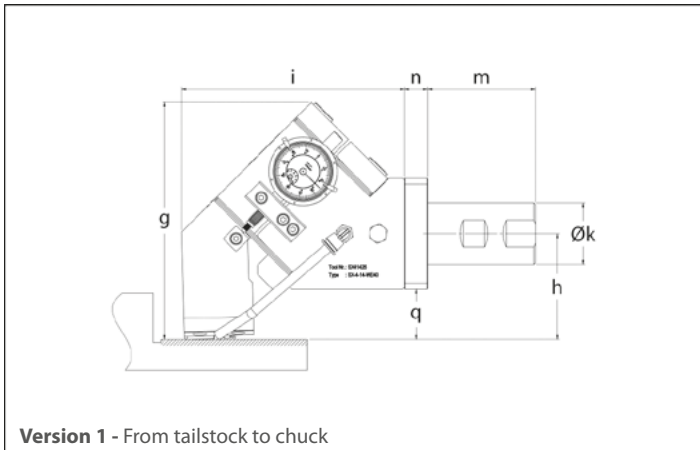

Dimensions

Tool type	Design	Shank	Height		Version 1		Version 2		Version 3		Version 4		n								
			a	b*	g	h	i	q	j	l	p	r		s	t	u	v	w	x	z	
SX	14	all types	56	72	154	68	145	32	129	44	170	171	122	98	134	165	122	158	129	15	
		VDI40		83																	
		VDI50		100						134	49										
		VDI60		123			165		139	54	177										

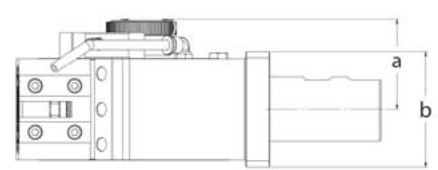

There is not "n" size at square tools

Product selection

SX Tool selection (complete)										Spare part selection						
Tool type	Design	Version	Shank					Tool type	Design	Support roller		Roller				
			VDI	Cylindrical		Square				Tool type	Design	Tool type	Design	Tool type	Design	
				DIN69880	DIN1835 A	DIN1835 B	SL									SLA
				($\varnothing k \times m$)	($\varnothing k \times m$)	($\varnothing k \times m$)	(d x e x f)									(d x e x f)
SX	14	1	VDI30($\varnothing 30 \times 55$)	ZA32($\varnothing 32 \times 60$)	ZS32($\varnothing 32 \times 60$)			SX	14	SX	14	SX	14			
		2	VDI40($\varnothing 40 \times 63$)	ZA40($\varnothing 40 \times 70$)	ZS40($\varnothing 40 \times 70$)	SL25(25x30x130)	SLA25(25x60x130)									
		3	VDI50($\varnothing 50 \times 78$)	ZA50($\varnothing 50 \times 80$)	ZS50($\varnothing 50 \times 80$)	SL32(32x30x130)	SLA32(32x60x130)									
		4	VDI60($\varnothing 60 \times 94$)	ZA63($\varnothing 63 \times 90$)	ZS63($\varnothing 63 \times 90$)											

All dimensions in mm.

How to order | Order samples

SX-14-1-VDI40 Single roller burnishing tool	SX-14 Cage	SX-14 Sup.roller	SX-14 Roller
---	------------	------------------	--------------

You can create order codes of the tool and spare parts by looking at the product selection table. For this, please rank the requested product features side by side.

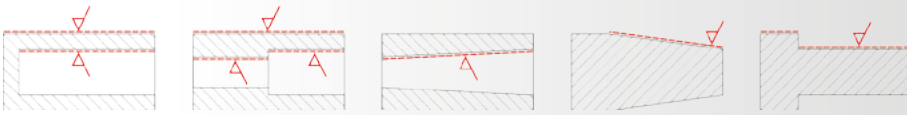

✓ Achievable surface roughness $Rz < 1\mu\text{m} / Ra < 0,16\mu\text{m}$

Limited length of holes, shafts and internal-external tapers

Hole and shaft process in one setting...

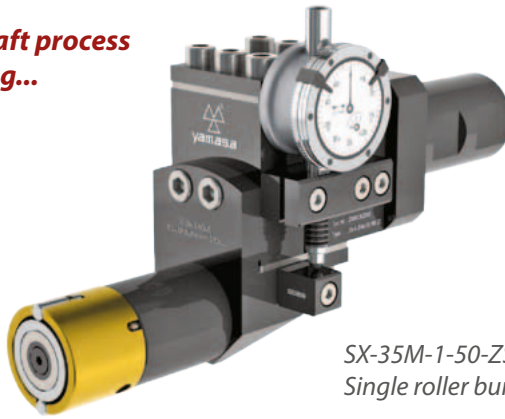

SX-35M-1-50-ZS32
Single roller burnishing tool

SX-35M Processing properties and parameters

Processable surface	Holes, shafts, internal and external tapers*
Working range	$\varnothing \geq 35$
Circumferential speed	max. 150 m/min.
Feed rate	max. 0,6 mm/rev.
Rolling share (int./ext.)	up to 0,03 / 0,02 mm
Rolling force	max. 5000 Newton
Pre-machining roughness	$Rz = 5 - 20\mu\text{m}$
Pre-machining	lathe or reaming
Coolant	Oil or emulsion

* Taper setting should be made for taper process.

- 1- Cage
- 2- Support roller
- 9- Roller
- 11- Roller head carrier
- 18- Tool body
- 19- Dial indicator (IP67)
 - waterproof
 - shockproof
- 27- Shank

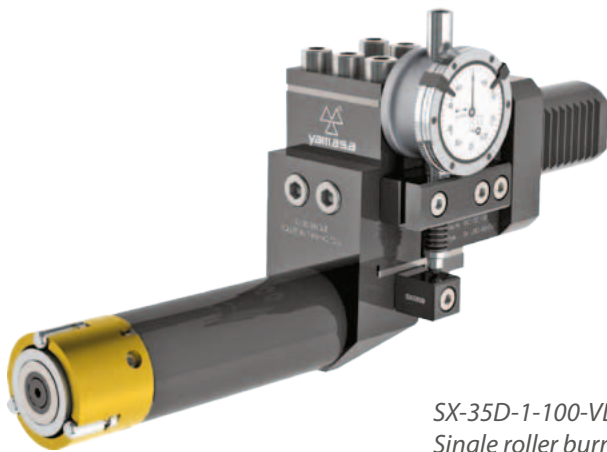
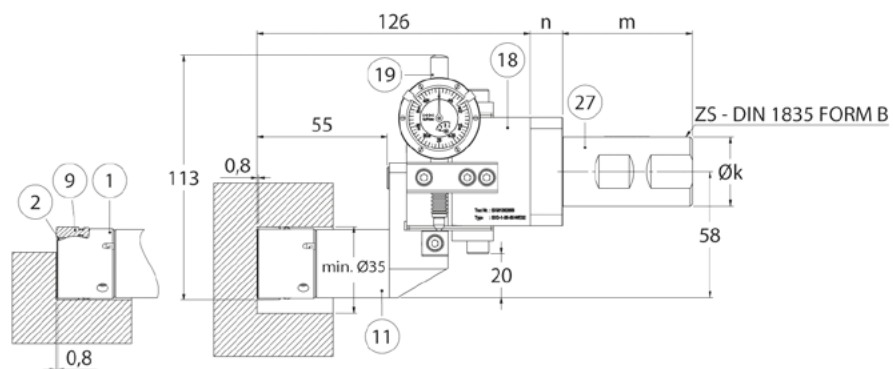

SX-35D-1-100-VDI30
Single roller burnishing tool

SX-35D Processing properties and parameters

Processable surface	Holes and internal tapers*
Working range	$\varnothing \geq 35$
Circumferential speed	max. 150 m/min.
Feed rate	max. 0,6 mm/rev.
Rolling share	up to 0,03 mm
Rolling force	max. 5000 Newton
Pre-machining roughness	$Rz = 5 - 20\mu\text{m}$
Pre-machining	lathe or reaming
Coolant	Oil or emulsion

* Taper setting should be made for taper process.

- 1- Cage
- 2- Support roller
- 9- Roller
- 11- Roller head carrier
- 18- Tool body
- 19- Dial indicator (IP67)
 - waterproof
 - shockproof
- 27- Shank

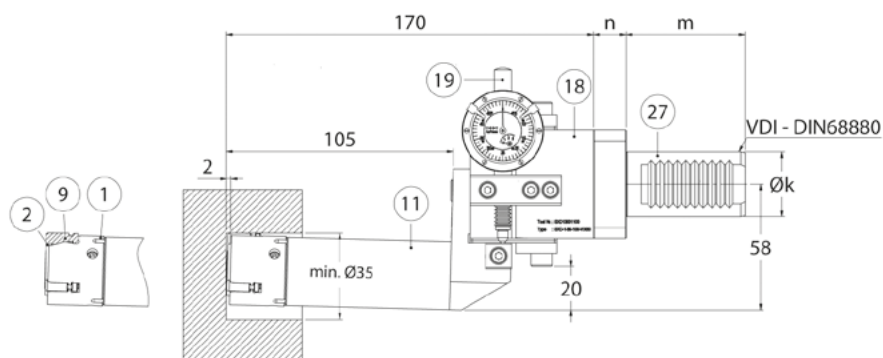

Single Roller Burnishing Tools

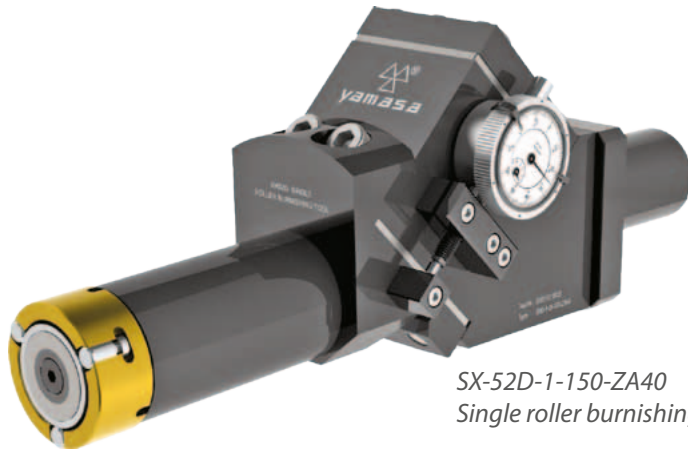

SX-52D-1-150-ZA40
Single roller burnishing tool

SX-52D Processing properties and parameters

Processable surface	Holes, shafts, internal and external tapers*
Working range	Ø ≥ 52
Circumferential speed	max. 150 m/min.
Feed rate	max. 0,6 mm/rev.
Rolling share (int./ext.)	up to 0,04 / 0,02 mm
Rolling force	max. 10000 Newton
Pre-machining roughness	Rz = 5 - 20 µm
Pre-machining	lathe or reaming
Coolant	Oil or emulsion

* Taper setting should be made for taper process.

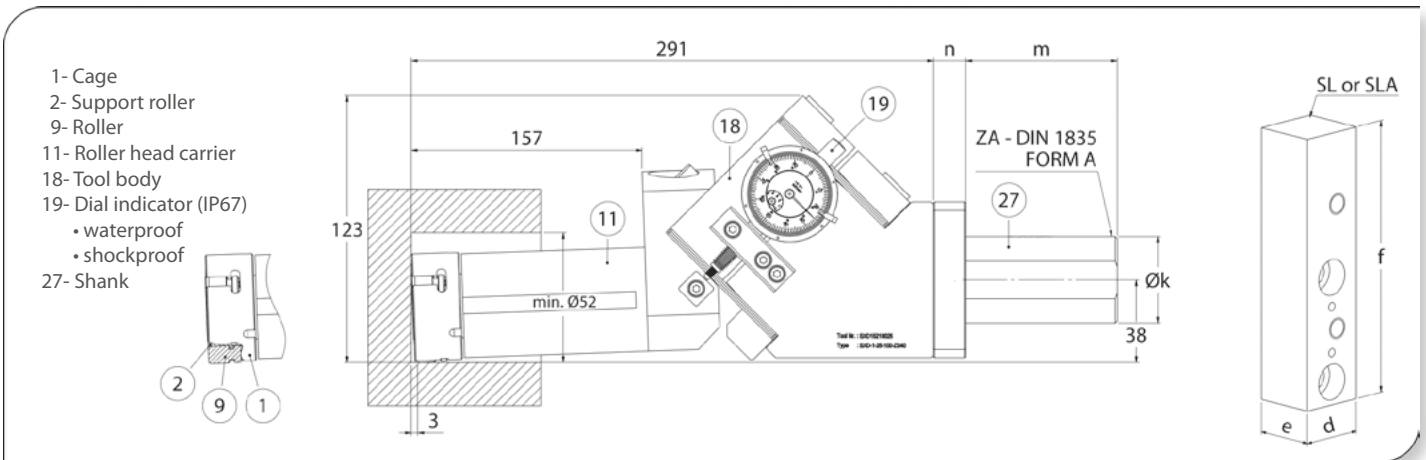

- 1- Cage
- 2- Support roller
- 9- Roller
- 11- Roller head carrier
- 18- Tool body
- 19- Dial indicator (IP67)
 - waterproof
 - shockproof
- 27- Shank

Hole machining

Tool type	Design	Hole depth (mm)						Work-piece
		<40	<60	<80	<100	<125	<150	
SX	35M	35	35	35	35	35	35	min. hole Ø-mm
	35D	35	36	36,5	37	37,5	38	
	52D	52	53	53,5	54	55	56	

* b = 60 mm for Ø40 mm cyl. and VDI shanks (SX-35M / SX-35D).
* b = 83 mm for Ø40 mm VDI shank (SX-52D).

Dimensions

Tool type	Design	Height		
		a	b*	n
SX	35M	43	50	15
	35D	43	50	15
	52D	56	72	15

* b = 100 mm for Ø50 mm VDI shank (SX-52D)
* b = 123 mm for Ø60 mm VDI shank (SX-52D)

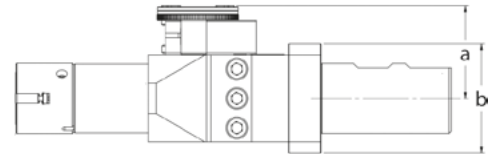

There is not "n" size at square shank tools.

Product selection

SX Tool selection (complete)						Spare part selection								
Tool type	Design	Ver- sion	Rolling length	Shank					SX Cage		Sup. Roller		Roller	
				VDI	Cylindrical		Square		Tool type	Design	Tool type	Design	Tool type	Design
				DIN69880 (Øk x m)	DIN1835 A (Øk x m)	DIN1835 B (Øk x m)	SL (d x e x f)	SLA (d x e x f)						
SX	35M 35D	1	50 100 150	VDI20(Ø20x40)	ZA20(Ø20x50)	ZS20(Ø20x50)	SL16(16x30x120)	SLA16(16x60x120)	SX	35M 35D	SX	35M 35D	SX	35M 35D
				VDI25(Ø25x48)	ZA25(Ø25x56)	ZS25(Ø25x56)	SL20(20x30x120)	SLA20(20x60x120)						
				VDI30(Ø30x55)	ZA32(Ø32x60)	ZS32(Ø32x60)	SL25(25x30x120)	SLA25(25x60x120)						
				VDI40(Ø40x63)	ZA40(Ø40x70)	ZS40(Ø40x70)	SL32(32x30x120)	SLA32(32x60x120)						
				VDI30(Ø30x55)	ZA32(Ø32x60)	ZS32(Ø32x60)	SL25(25x30x130)	SLA25(25x60x130)						
				VDI40(Ø40x63)	ZA40(Ø40x70)	ZS40(Ø40x70)	SL32(32x30x130)	SLA32(32x60x130)						
	52D		VDI150(Ø50x78)	ZA50(Ø50x80)	ZS50(Ø50x80)	SL32(32x30x130)	SLA32(32x60x130)	SX	52D	SX	52D	SX	52D	
			VDI160(Ø60x94)	ZA63(Ø63x90)	ZS63(Ø63x90)									

All dimensions in mm.

How to order | Order samples

SX-35M-1-50-ZS32 Single roller burnishing tool	SX-35M Cage	SX-35M S.Rol.	SX-35M Roll.
SX-35D-1-100-VDI30 Single roller burnishing tool	SX-35D Cage	SX-35D S.Rol.	SX-35D Roll.
SX-52D-1-150-ZA40 Single roller burnishing tool	SX-52D Cage	SX-52D S.Rol.	SX-52D Roll.

You can create order codes of the tool and spare parts by looking at the product selection table. For this, please rank the requested product features side by side.

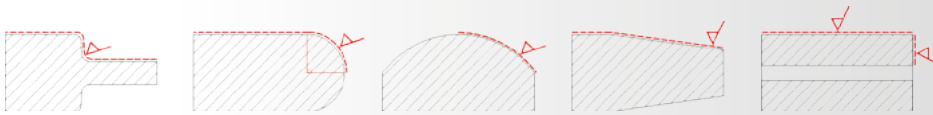

✓ Achievable surface roughness $Rz < 1 \mu\text{m}$ / $Ra < 0,16 \mu\text{m}$

Fillets, Radii, contours, and spherical surface

Application

- Tools burnish contours, radii, cylindrical, spherical, tapered and flat surfaces.
- Provide time saving through a high processing power and speed.
- Provide surface hardness and at low rate calibration (measurement accuracy).
- Easy to change the spare parts.
- Short process time. No sawdust.
- Needs min. lubrication (oil or emulsion),

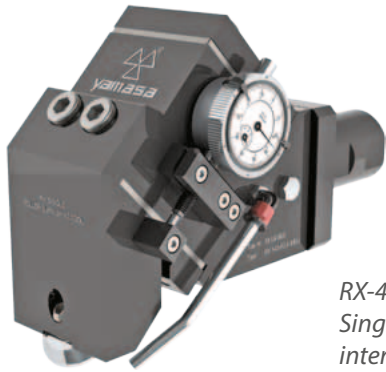

*RX-45-1-R2,5-ZS40
Single roller burnishing tool
internal coolant*

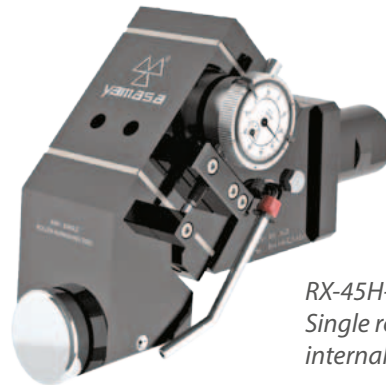

*RX-45H-1-R2,5-ZS40
Single roller burnishing tool
internal coolant*

RX-45 Processing properties and parameters

Processable surfaces	Cylindrical and radii up to the face
Machinable materials	low and midlevel strength
Circumferential speed	max. 300 m/min.
Feed rate	max. 1 mm/rev.
Rolling share	up to 0,03 mm
Rolling force	max. 4000 Newton
Pre-machining roughness	$Rz = 5 - 30 \mu\text{m}$
Coolant	Oil or emulsion

RX-45H Processing properties and parameters

Processable surfaces	Cylindrical and radii up to 75°
Machinable materials	High strength
Circumferential speed	max. 300 m/min.
Feed rate	max. 1 mm/rev.
Rolling share	up to 0,03 mm
Rolling force	max. 10000 Newton
Pre-machining roughness	$Rz = 5 - 30 \mu\text{m}$
Coolant	Oil or emulsion

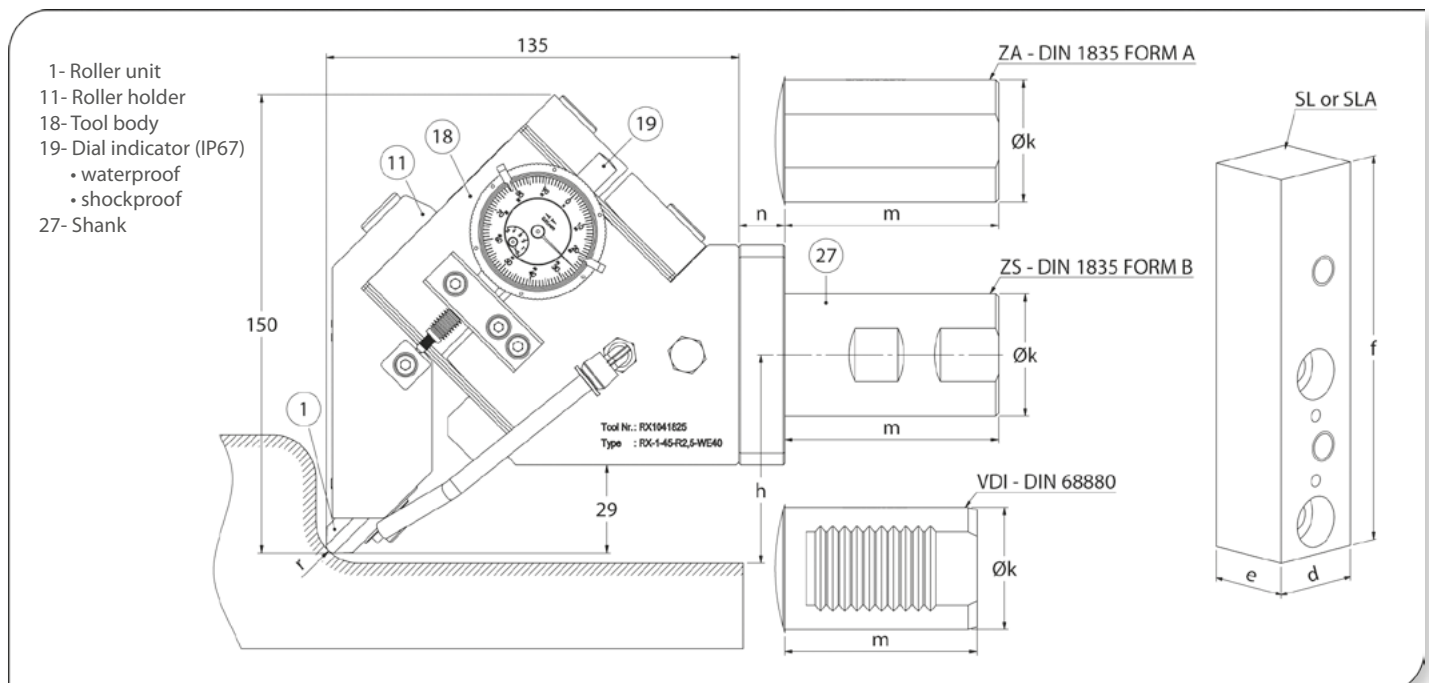

RX tools are available for deep rollig applications. Please ask.

Technical features and advantages

- Burnishing different sizes with same tool.
- Used on CNC, universal and lathe machines with copy systems.
- Tool design allows either right or left hand operation.
- Don't require settings and when the tool is fixed to the machine, it is ready to use.
- Roller burnishing force is adjustable, so it is possible to achieve high quality and standard roughness values.
- Spring system apply rolling force consistently. So it provides high quality and standard work flow.
- Shoulders and other edges is possible up to the end.
- Burnishing all kinds of metallic materials up to the tensile strength of 1400N/mm² and to the hardness 42-45 HRC.

Single Roller Burnishing Tools

Tool structure

- Tools consist of a connecting shank, precision body, roller head and a dial indicator which shows rolling force.
- Dial indicator is IP67 protected and has a waterproof-shockproof structure.
- Square, cylindrical or VDI shanks are available.

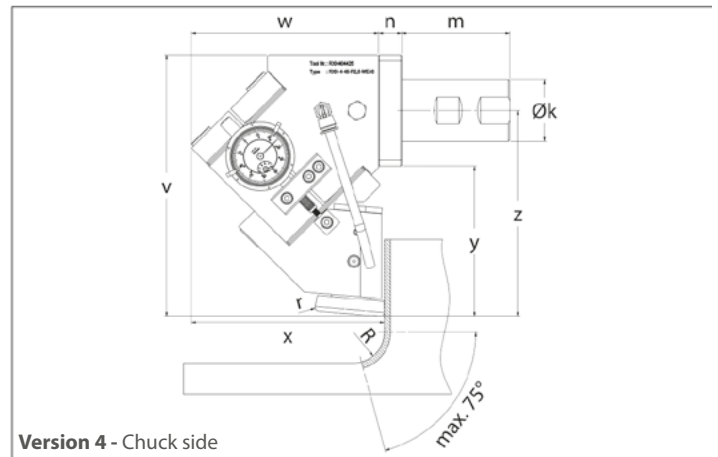
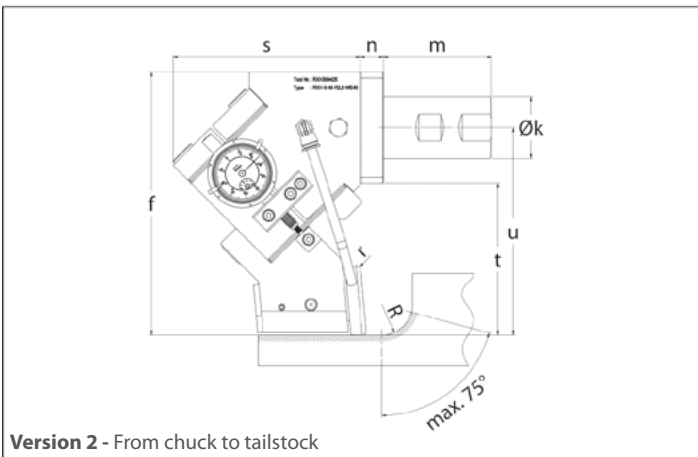
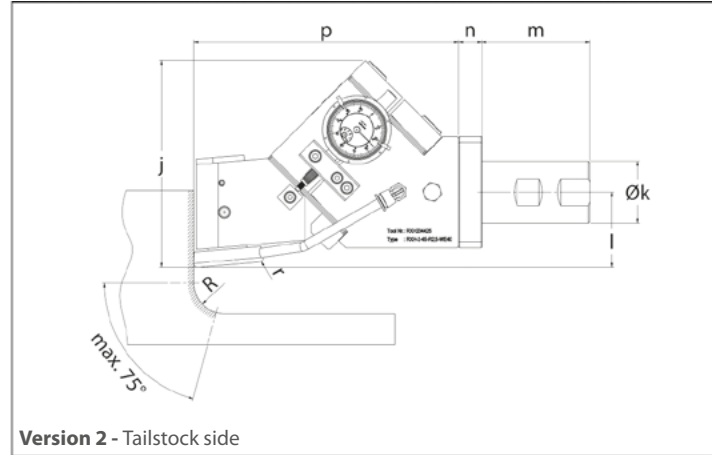
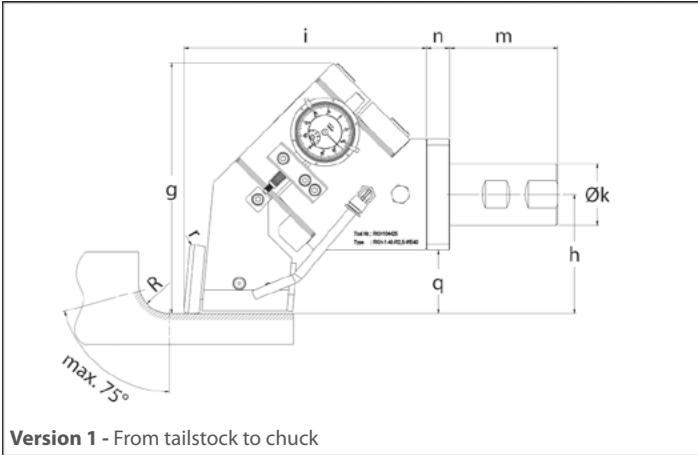

Dimensions

Tool type	Design	Shank	Height		Version 1		Version 2		Version 3			Version 4					n					
			a	b*	g	h	i	q	j	l	p	f	s	t	u	v		w	x	z	y	
RX	45 45H	all types	56	72	163	77	157	41	134	49	172	171	122	98	134	170	122	125	133	97	15	
		VDI40		83																		
		VDI50		100																		
		VDI60		123			165				177		129									

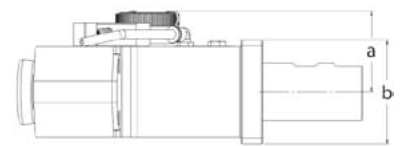

There is not "n" size at square shank tools.

Product selection

Tool selection (complete)										Spare roller unit		
Tool type	Design	Version	Roller radii (R*)	Shank					Tool type	Design	Roller radii (R*)	
				VDI		Cylindrical		Square				
				DIN69880	DIN1835 A	DIN1835 B	SL	SLA				
				(Øk x m)	(Øk x m)	(Øk x m)	(d x e x f)	(d x e x f)				
RX	45	1	0,8	VDI30(Ø30x55)	ZA32(Ø32x60)	ZS32(Ø32x60)	SL25(25x30x130)	SLA25(25x60x130)	RX	45	0,8	
			1,2	VDI40(Ø40x63)	ZA40(Ø40x70)	ZS40(Ø40x70)					1,2	
45H	1	2	1,6	VDI50(Ø50x78)	ZA50(Ø50x80)	ZS50(Ø50x80)	SL32(32x30x130)	SLA32(32x60x130)		45H	1,6	
			2,5	VDI60(Ø60x94)	ZA63(Ø63x90)	ZS63(Ø63x90)					2,5	
		3	4,0							4,0		
		4	6,0							6,0		

* Roller Radii max. R4,0 is possible for RX-45 type. All dimensions in mm.

How to order | Order samples

RX-45H-1-R2,5-VDI40 Single roller burnishing tool	RX-45H-R2,5 Roller unit
---	-------------------------

You can create order codes of the tool and spare parts by looking at the product selection table. For this, please rank the requested product features side by side.

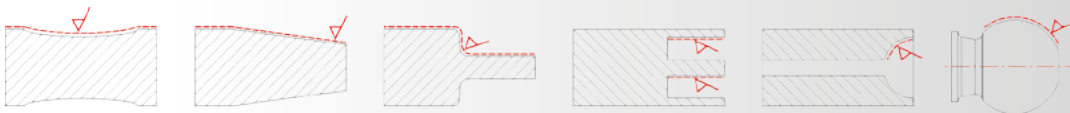

Spherical surfaces, contours, radii, fillets and groove flanks

✓ Achievable surface roughness $Rz < 1 \mu\text{m} / Ra < 0,16 \mu\text{m}$

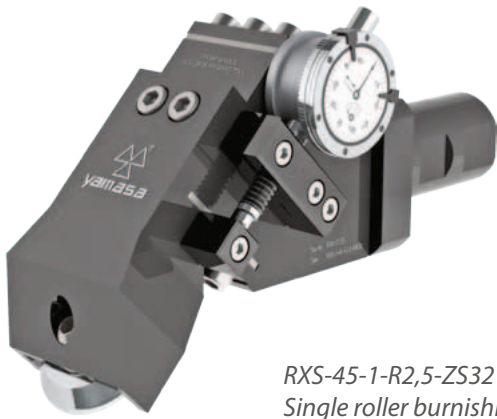

RXS-45-1-R2,5-ZS32
Single roller burnishing tool

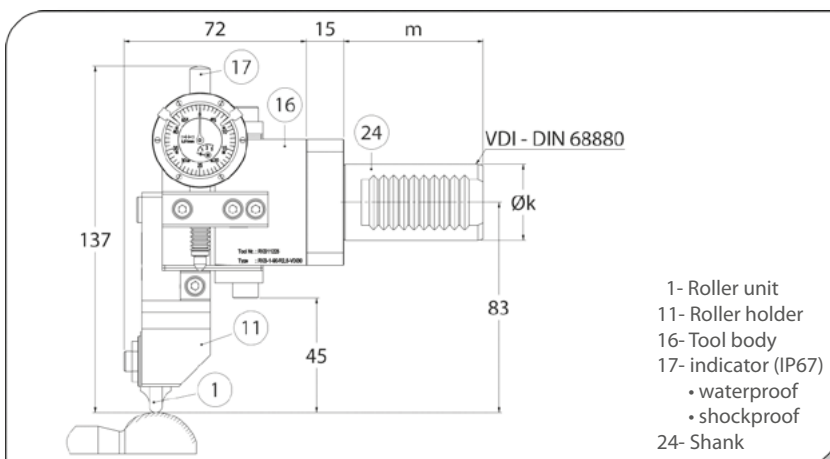
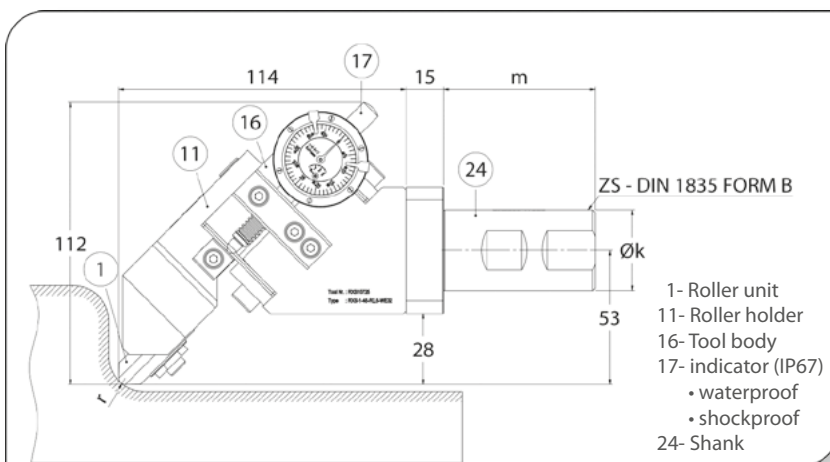

RXS-90-1-R2,5-VDI30
Single roller burnishing tool

RXS-45 Processing properties and parameters

Processable surfaces	Cylindrical and radii up to the plane face
Machinable materials	low and midlevel strength
Circumferential speed	max. 300 m/min.
Feed rate	max. 0,8 mm/rev.
Rolling share	up to 0,02 mm
Rolling force	max. 4000 Newton
Pre-machining roughness	$Rz = 5 - 20 \mu\text{m}$
Coolant	Oil or emulsion

Application

- Tools burnish spherical surfaces, contours, cylindrical surfaces with connecting radius up to the flat surface, groove flanks, tapered and flat surfaces.
- Process is done in one pass after pre-machining.
- Provide surface hardness and at low rate calibration (measurement accuracy).

Technical features and advantages

- Burnishing different sizes with same tool.
- Used on CNC and Universal lathe machines.
- Tool design allows either right or left hand operation.
- Don't require settings and when the tool is fixed to the machine, it is ready to use.
- Roller burnishing force is adjustable, so it is possible to achieve high quality and standard roughness values.
- Spring system apply rolling force consistently. So it provides high quality and standard work flow.
- Shoulders and other edges is possible up to the end.
- Burnishing all kinds of metallic materials up to the tensile strength of $1400\text{N}/\text{mm}^2$ and to the hardness 45 HRC.
- Easy to change the spare parts.
- Short process time.
- Needs min. lubrication (oil or emulsion).
- No sawdust.

RXS-90 Processing properties and parameters

Processable surfaces	Spherical surface and contours
Machinable materials	low and midlevel strength
Circumferential speed	max. 300 m/min.
Feed rate	max. 0,8 mm/rev.
Rolling share	Up to 0,02 mm
Rolling force	max. 4000 Newton
Pre-machining roughness	$Rz = 5 - 20 \mu\text{m}$
Coolant	Oil or emulsion

Single Roller Burnishing Tools

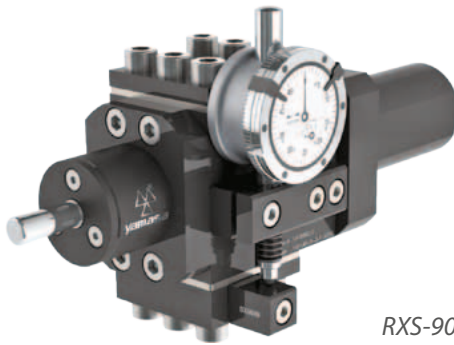

RXS-90P-1-8x20-ZA32
Single roller burnishing tool

RXS-90P Processing properties and parameters

Processable surfaces	Spherical holes, groove flanks, circular ring areas
Machinable materials	low and midlevel strength
Circumferential speed	max. 150 m/min.
Feed rate	max. 0,4 mm/rev.
Rolling share	up to 0,02 mm
Rolling force	max. 4000 Newton
Pre-machining roughness	Rz = 5 - 20 µm
Coolant	Oil or emulsion

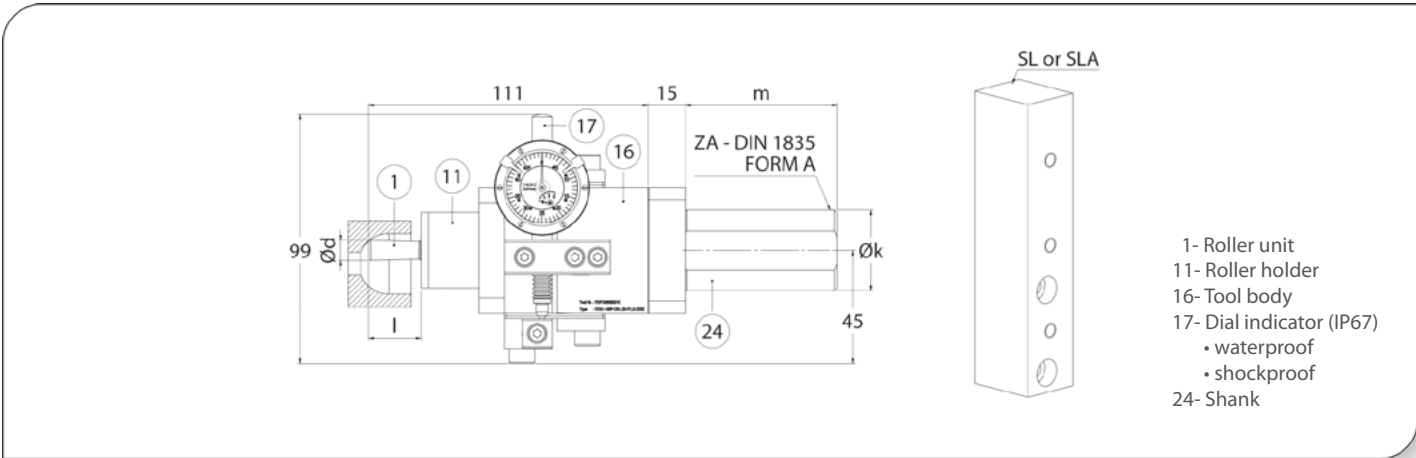

Tool structure

- Tools consist of a connecting shank, precision body, roller head and a dial indicator which shows rolling force.
- Dial indicator is IP67 protected, has a waterproof-shockproof structure.
- Square, cylindrical or VDI shanks are available.

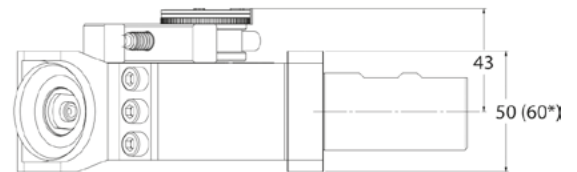

*60: for the tools with Ø40 mm VDI and cylindrical shank.

Product selection

Tool type	Design	Version	Roller radii (R*)	Tool selection (complete)					Spare roller unit		
				Shank					Tool type	Design	Roller radii (R*)
				VDI	Cylindrical		Square				
DIN69880 (Øk x m)	DIN1835 A (Øk x m)	DIN1835 B (Øk x m)	SL (d x e x f)	SLA (d x e x f)							
RXS	45	1	0,8	VDI20(Ø20x40)	ZA20(Ø20x50)	ZS20(Ø20x50)	SL16(16x30x120)	SLA16(16x60x120)	RXS	45	0,8
			1,2								1,2
			1,6								1,6
	90		2,5	VDI25(Ø25x48)	ZA25(Ø25x56)	ZS25(Ø25x56)	SL20(20x30x120)	SLA20(20x60x120)		90	2,5
			4,0								4,0
			4,0								4,0
	90P		(Ødxl)	VDI40(Ø40x63)	ZA40(Ø40x70)	ZS40(Ø40x70)	SL32(32x30x120)	SLA32(32x60x120)		90P	(Ødxl)
			08x20								08x20
			11x30								11x30

All dimensions in mm.

How to order | Order samples

RXS-45-1-R2,5-ZS32 Single roller burnishing tool	RXS-45-R2,5 Roller unit
RXS-90-1-R2,5-VDI30 Single roller burnishing tool	RXS-90-R2,5 Roller unit
RXS-90P-1-8x20-ZA32 Single roller burnishing tool	RXS-90P-8x20 Roller unit

You can create order codes of the tool and spare parts by looking at the product selection table. For this, please rank the requested product features side by side.

✓ Achievable surface roughness $Rz < 1 \mu\text{m} / Ra < 0,16 \mu\text{m}$

Technical features

CEOS type combined skive-burnishing tools simultaneously skive and burnish the cold drawn and hot rolled tubes. The tools are produced between $\varnothing 38-400$ mm and as standard with 2 and 3 skiving knives. Cutting depth is possible up to 3 mm in diameter.

The diameter of tools is adjustable, adjust capacity is changing between 0.3-0.8 mm. Skiving head and roller head is adjusted independently from each other, adjustment mechanism is very precisely, and allows setting to be made in 0.01 mm increments.

CEOS tools, can produce finished tubes with the help of high precisely knife system which can machine rough finish process in one adjustment and one pass till H7 tolerances. Improved integrated roller head harden the inner surface of the tube and burnish it in $Ra < 0,1 \mu\text{m}$ roughness like a mirror.

Both side retract system is available on tools. After retract any scratching problem never occurs. There is a system on CEOS type combined skive-burnishing tools which eliminates misalignments, axis failures and wobbling. It is possible to produce with these tools 0,4 - 20 meter long tubes. The tools have long using life, and it is possible to use the tools for a long time without size change due to abrasion.

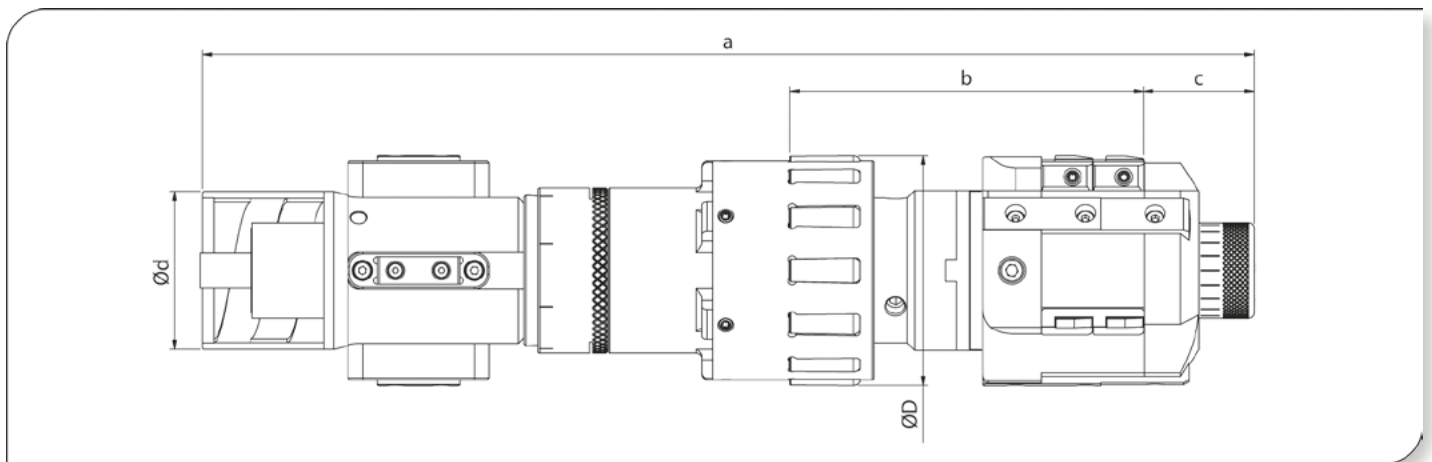

Tool type	Diameter range	BTA* boring bar	Tool connection system		Setting range		Main dimensions		
	ØD	Ød	International	Europe	Skive head	Roller head	a	b	c
CEOS	038 - 049	33	IR033 BTA Female	ER033 BTA Female	NominalØ ±0,15	Nom.Ø +0,25/-0,1	438	154	47
	050 - 064	43	IR043 BTA Female	ER043 BTA Female	NominalØ ±0,25	NominalØ ±0,25	439	154	47
	065 - 079	56	IR056 BTA Female	ER056 BTA Female	NominalØ ±0,25	NominalØ ±0,25	444	163	47
	080 - 099	68	IR068 BTA Female	ER068 BTA Female	NominalØ ±0,25	NominalØ ±0,25	464	165	47
	100 - 139	82	IR082 BTA Female	ER082 BTA Female	NominalØ ±0,40	NominalØ ±0,40	573	193	60
	140 - 179	118	IR118 BTA Female	ER118 BTA Female	NominalØ ±0,40	NominalØ ±0,40	573	193	60
	180 - 209	142	IR142 BTA Female	ER142 BTA Female	NominalØ ±0,40	NominalØ ±0,40	573	193	60
	210 - 300	178	IR178 BTA Female	ER178 BTA Female	NominalØ ±0,40	NominalØ ±0,40	573	193	60

*It is possible to produce the tools for boring bars with different sizes.

All Dimensions in mm.

Tool connection and hydraulics control

BTA connection system is available on tools. The tool is connected and disconnected only one movement on the boring bar. There are two types of control systems available on the tools that meet the requirements in the market.

1-) International system

- Activation cylinder is integrated on the tool.
- Tool can be controlled in hydraulics and pneumatics or both system.
- System works with 40-100 hydraulic bar pressure.

2-) Europe system

- Activation cylinder is integrated on boring bar.
- Control is done from boring bar.
- System works with approx. 20 bar pressure.

Combined Skive-Burnishing Tools

Developed system

YAMASA CEOS new generation combined skive-burnishing tools offer many innovations. These tool offers high performance and eliminate many problems experienced with the customary tools. YAMASA CEOS is a competitive tools which reduce the production costs extremely.

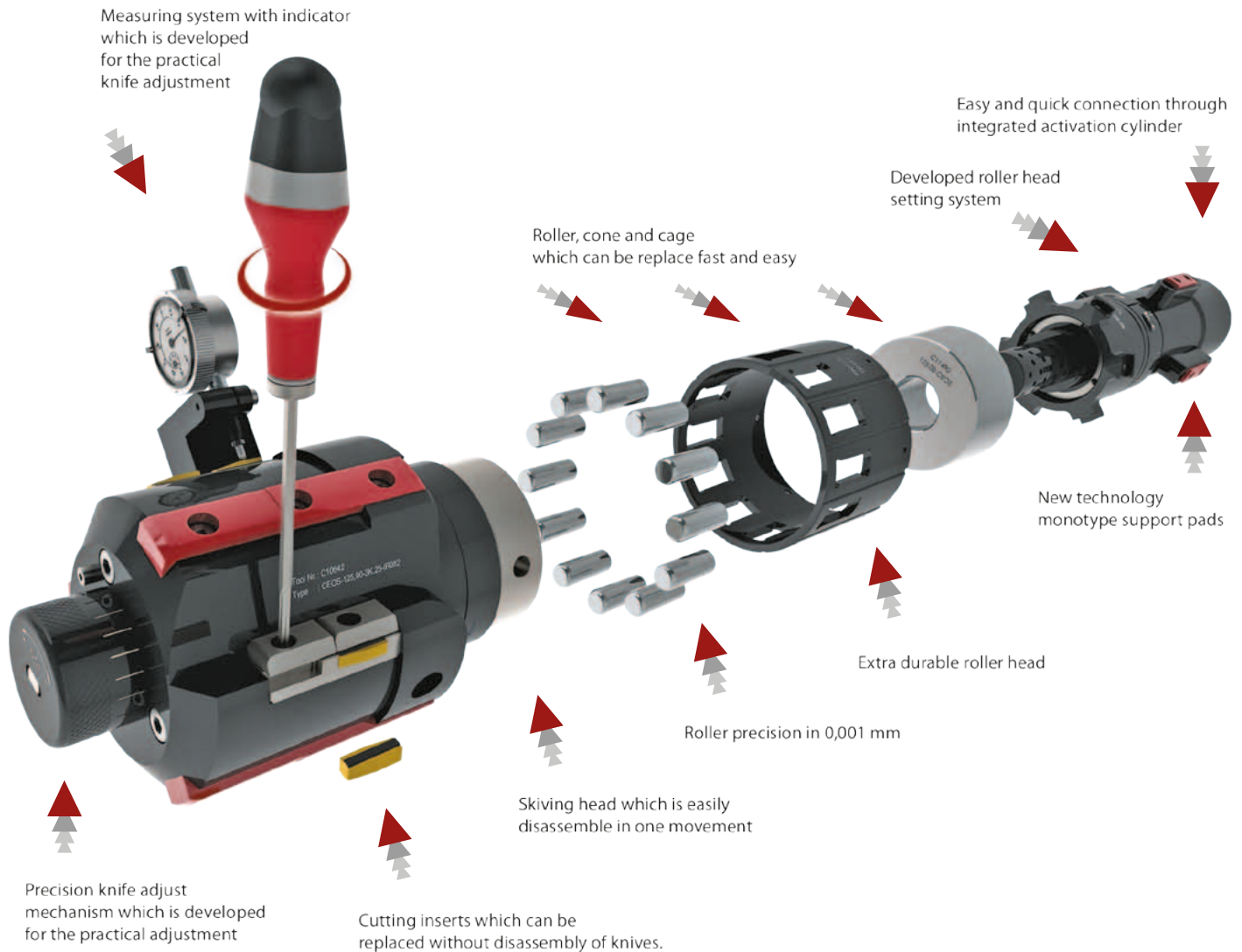

- Minimized process time (Vc=300 m/min, Feeding=up to 5mm/rev)
- Cutting depth up to 3 mm in diameter, high cutting performance
- Pneumatic and hydraulic control with integrated switch system
- Excellent oil flow design, maximum coolant
- Improved knife mechanism, eliminate the scratch problems after retract
- H7 tolerance, 0,01 mm circular shape and minimized longitudinal wavyness with improved skiving technology
- Avoidance or reduction of rippling
- Excellent knife system which machine irregular holes in one pass
- Simple and quick replacement of the spare parts! minimum waste of time!

✓ Achievable surface roughness Rz<1µm / Ra<0,16 µm

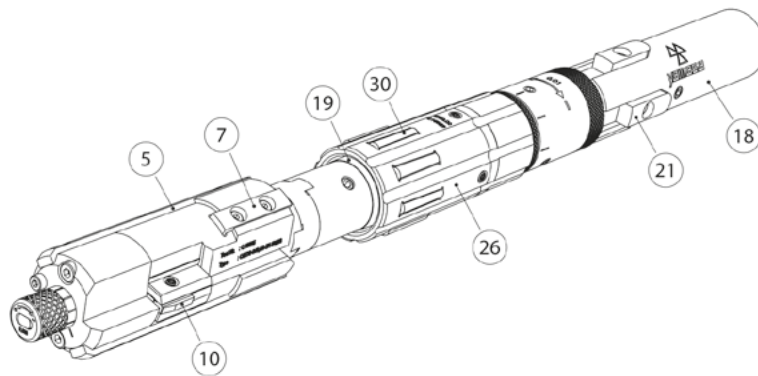
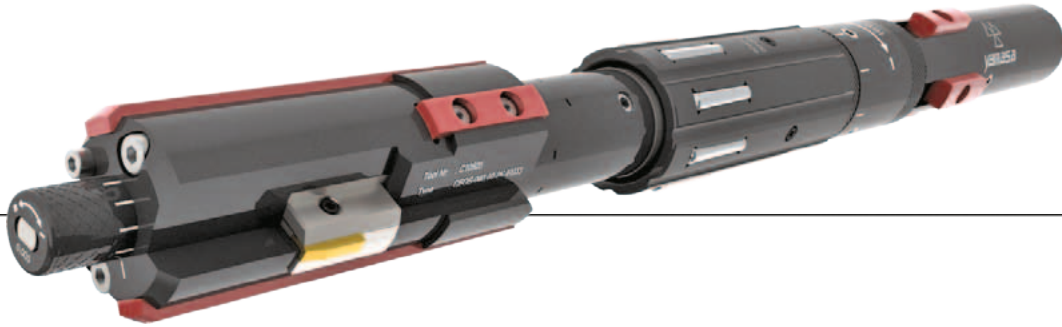

- 5- Guide pad (front)
- 7- Guide pad (back)
- 10- Cutting insert
- 18- Shank
- 19- Cone
- 21- Support pad
- 26- Cage
- 30- Roller

Recommended machining parameters

Dia.Range	Revolution	Feeding	Coolant flow	Cutting depth	Torque	Motor power	Attainability	
Ø-mm	rev/min	mm/rev	L/min	Ø-mm	Nm	kW	Tolerance	up to H7
38 - 40	1500	2	120 - 160	0,5 (max.1,5 opt.)	40	20	Circle regularity	up to 0,01 mm
41 - 49	1200	2	150 - 200	0,5 (max.1,5 opt.)	50		Roughness	Ra<0,1 / Rz<1µm

Product selection

CEOS tool selection				Spare part selection											
Complete tool		Connection system		Roller		Cutting insert		Guide pad		Support pad		Cone		Cage	
Ø-mm	Code	International	Europe	Code	Pc	Code	Pc	Code	Pc	Code	Pc	Code	Pc	Code	Pc
38,00	C10501	IR033 BTA Female	ER033 BTA Female	C11886	8	C11883	2	C11773 (5) C11774 (7)	2 2	4	C11781	C11349	C10925	1	1
39,00	C10503										C11783	C11351	C10927		
40,00	C10505										C11785	C11353	C10929		
41,00	C10506										C11786	C11354	C10930		
42,00	C10508										C11788	C11356	C10932		
43,00	C10510										C11790	C11358	C10934		
44,00	C10511										C11791	C11359	C10935		
45,00	C10513										C11793	C11361	C10937		
46,00	C10514										C11794	C11362	C10938		
47,00	C10516										C11796	C11364	C10940		
48,00	C10518										C11798	C11366	C10942		
49,00	C10519										C11799	C11367	C10943		

How to order | Order samples

It is enough to inform the code and quantities of the product you wish to order. For example C11883 x 8 pc. Please ask interval sizes which do not exist on the tables. On the choice of Europe connection system, letter "E" is added at the end of the complete tool code. Such as C10501E.

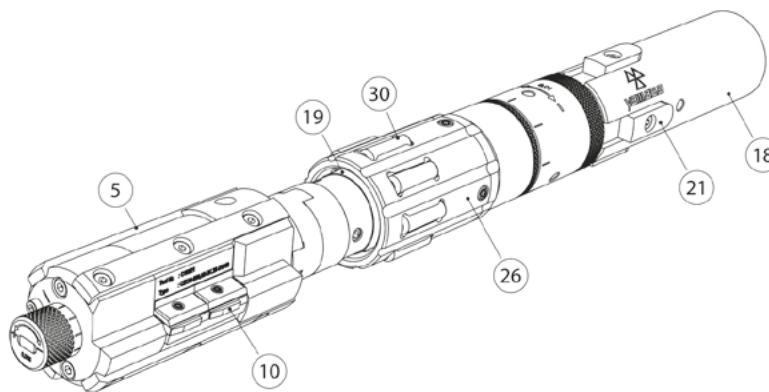
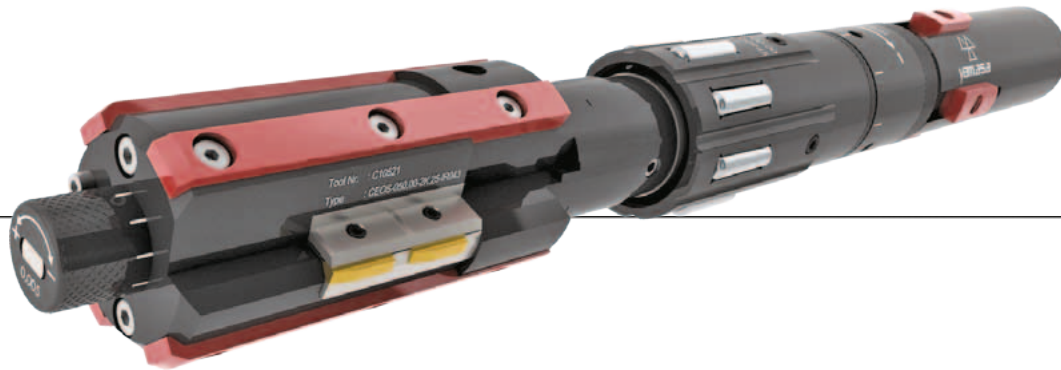

- 5- Guide pad
- 10- Cutting insert
- 18- Shank
- 19- Cone
- 21- Support pad
- 26- Cage
- 30- Roller

Recommended machining parameters

Dia.Range	Revolution	Feeding	Coolant flow	Cutting depth	Torque	Motor power	Attainability
Ø-mm	rev/min	mm/rev	L/min	Ø-mm	Nm	kW	
50 - 57	1100 (max.1700)	2 (max.4)	170 - 230	0,7 (max.2 opt.)	60	20 - 30	Tolerance up to H7
58 - 64	1000 (max.1500)	2 (max.4)	190 - 260	0,7 (max.2 opt.)	65		Circle regularity up to 0,01 mm
							Roughness Ra<0,1 / Rz<1µm

Product selection

CEOS tool selection				Spare part selection											
Complete tool		Connection system		Roller		Cutting insert		Guide pad		Support pad		Cone		Cage	
Ø-mm	Code	International	Europe	Code	Pc	Code	Pc	Code	Pc	Code	Pc	Code	Pc	Code	Pc
50,00	C10521	IR043 BTA Female	ER043 BTA Female	C11887	8	C11883	4	C11775	4	C11801	4	C11369	1	C10945	1
51,00	C10523									C11803		C11371		C10947	
52,00	C10524									C11804		C11372		C10948	
53,00	C10526									C11806		C11374		C10950	
54,00	C10528									C11808		C11376		C10952	
55,00	C10529									C11809		C11377		C10953	
56,00	C10531									C11811		C11379		C10955	
57,00	C10532									C11812		C11380		C10956	
58,00	C10534									C11814		C11382		C10958	
59,00	C10536									C11816		C11384		C10960	
60,00	C10537									C11817		C11385		C10961	
61,00	C10539									C11819		C11387		C10963	
62,00	C10541									C11821		C11389		C10965	
63,00	C10542									C11822		C11390		C10966	
64,00	C10544									C11824		C11392		C10968	

How to order | Order samples

It is enough to inform the code and quantities of the product you wish to order. For example C11883 x 8 pc. Please ask interval sizes which do not exist on the tables. On the choice of Europe connection system, letter "E" is added at the end of the complete tool code. Such as C10501E.

✓ Achievable surface roughness Rz<1µm / Ra<0,16 µm

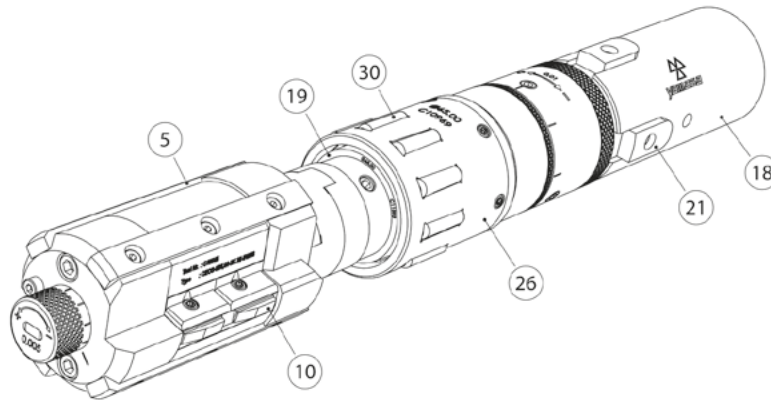

- 5- Guide pad
- 10- Cutting insert
- 18- Shank
- 19- Cone
- 21- Support pad
- 26- Cage
- 30- Roller

Recommended machining parameters

Dia.Range	Revolution	Feeding	Coolant flow	Cutting depth	Torque	Motor power	Attainability	
Ø-mm	rev/min	mm/rev	L/min	Ø-mm	Nm	kW	Tolerance	up to H7
65 - 72	900 (max.1400)	2,5(max.4)	210 - 290	1 (max.3 opt.)	75	30 - 40	Circle regularity	up to 0,01 mm
73 - 79	800 (max.1200)	2,5(max.4)	240 - 320	1 (max.3 opt.)	80		Roughness	Ra<0,1 / Rz<1µm

Product selection

CEOS tool selection				Spare part selection											
Complete tool		Connection system		Roller		Cutting insert		Guide pad		Support pad		Cone		Cage	
Ø-mm	Code	International	Europe	Code	Pc	Code	Pc	Code	Pc	Code	Pc	Code	Pc	Code	Pc
65,00	C10545	IR056 BTA Female	ER056 BTA Female	C11887	10	C11884	4	C11776	4	C11825	C11393	C10969	1	1	
66,00	C10547									C11827	C11395	C10971			
67,00	C10549									C11829	C11397	C10973			
68,00	C10550									C11830	C11398	C10974			
69,00	C10552									C11832	C11400	C10976			
70,00	C10554									C11834	C11402	C10978			
71,00	C10555									C11835	C11403	C10979			
72,00	C10557									C11837	C11405	C10981			
73,00	C10558									C11838	C11406	C10982			
74,00	C10560									C11840	C11408	C10984			
75,00	C10562									C11842	C11410	C10986			
76,00	C10563									C11843	C11411	C10987			
77,00	C10565									C11845	C11413	C10989			
78,00	C10567									C11847	C11415	C10991			
79,00	C10568									C11848	C11416	C10992			

How to order | Order samples

It is enough to inform the code and quantities of the product you wish to order. For example C11883 x 8 pc. Please ask interval sizes which do not exist on the tables. On the choice of Europe connection system, letter "E" is added at the end of the complete tool code. Such as C10501E.

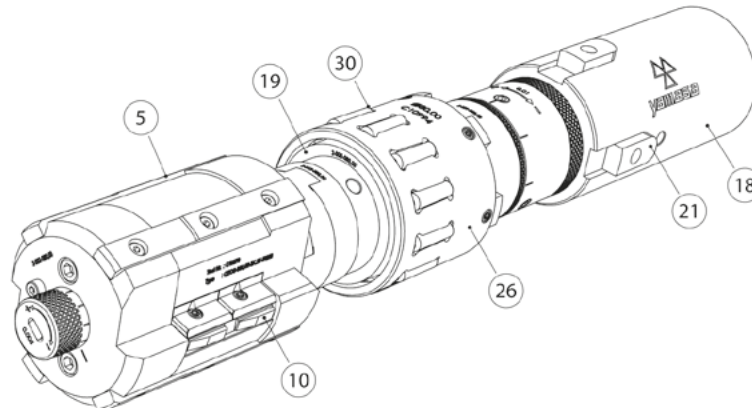

- 5- Guide pad
- 10- Cutting insert
- 18- Shank
- 19- Cone
- 21- Support pad
- 26- Cage
- 30- Roller

Recommended machining parameters

Dia.Range	Revolution	Feeding	Coolant flow	Cutting depth	Torque	Motor power	Attainability
Ø-mm	rev/min	mm/rev	L/min	Ø-mm	Nm	kW	
80 - 89	700 (max.1100)	3 (max.4)	270 - 360	1 (max.3 opt.)	90	30 - 40	Tolerance up to H7
90 - 99	640 (max.1000)	3 (max.4)	300 - 400	1 (max.3 opt.)	100		Circle regularity up to 0,01 mm
							Roughness Ra<0,1 / Rz<1µm

Product selection

CEOS tool selection				Spare part selection											
Complete tool		Connection system		Roller		Cutting insert		Guide pad		Support pad		Cone		Cage	
Ø-mm	Code	International	Europe	Code	Pc	Code	Pc	Code	Pc	Code	Pc	Code	Pc	Code	Pc
80,00	C10570	IR068 BTA Female	ER068 BTA Female	C11887	12	C11884	4	C11776	4	C11850	4	C11418	1	C10994	1
81,00	C10572									C11852		C11420		C10996	
82,00	C10573									C11853		C11421		C10997	
83,00	C10575									C11855		C11423		C10999	
84,00	C10576									C11856		C11424		C11000	
85,00	C10578									C11858		C11426		C11002	
86,00	C10580									C11860		C11428		C11004	
87,00	C10581									C11861		C11429		C11005	
88,00	C10583									C11863		C11431		C11007	
89,00	C10585									C11865		C11433		C11009	
90,00	C10586									C11866		C11434		C11010	
91,00	C10588									C11868		C11436		C11012	
92,00	C10589									C11869		C11437		C11013	
95,00	C10594									C11874		C11442		C11018	
99,00	C10601									C11881		C11449		C11025	

How to order | Order samples

It is enough to inform the code and quantities of the product you wish to order. For example C11883 x 8 pc. Please ask interval sizes which do not exist on the tables. On the choice of Europe connection system, letter "E" is added at the end of the complete tool code. Such as C10501E.

✓ Achievable surface roughness Rz < 1 µm / Ra < 0,16 µm

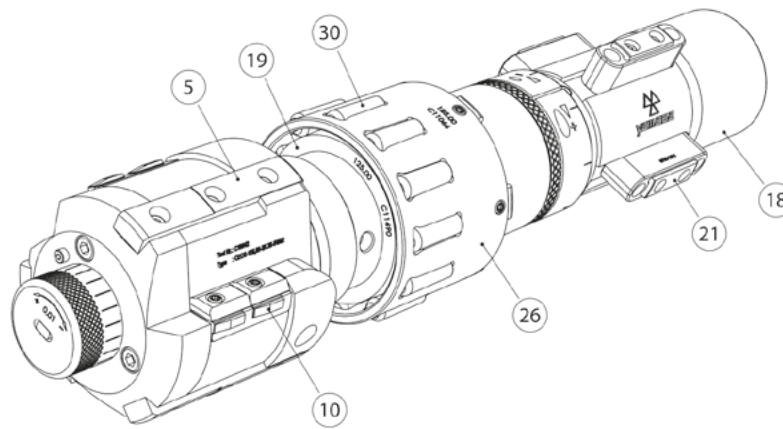

- 5- Guide pad
- 10- Cutting insert
- 18- Shank
- 19- Cone
- 21- Support pad
- 26- Cage
- 30- Roller

Attainability

Tolerance	up to H7
Circle regularity	up to 0,01 mm
Roughness	Ra < 0,1 / Rz < 1 µm

Recommended machining parameters

Dia. Range	Revolution	Coolant flow	Torque	Dia. Range	Revolution	Coolant flow	Torque	Feeding (mm/rev)	3,5 (max.4)
Ø-mm	rev/min	L/min	Nm	Ø-mm	rev/min	L/min	Nm	Cutting depth (Ø-mm)	1 (max.3 opt.)
100 - 109	580 (max.900)	330 - 440	180	120 - 129	500 (max.750)	390 - 520	220	Motor power (kW)	40 - 50
110 - 119	530 (max.800)	360 - 480	200	130 - 139	450 (max.700)	420 - 560	230		

Product selection

CEOS tool selection				Spare part selection											
Complete tool		Connection system		Roller		Cutting insert		Guide pad		Support pad		Cone		Cage	
Ø-mm	Code	International	Europe	Code	Pc	Code	Pc	Code	Pc	Code	Pc	Code	Pc	Code	Pc
100,00	C10602	IR082 BTA Female	ER082 BTA Female	C11888	10	C11884	6	C11777	3	C11882	4	C11450	1	C11026	1
105,00	C10610											C11458		C11034	
109,00	C10616											C11464		C11040	
110,00	C10618											C11466		C11042	
115,00	C10626											C11474		C11050	
120,00	C10634											C11482		C11058	
125,00	C10642											C11490		C11066	
130,00	C10649											C11497		C11073	
135,00	C10658											C11506		C11082	
139,00	C10664											C11512		C11088	

How to order | Order samples

It is enough to inform the code and quantities of the product you wish to order. For example C11883 x 8 pc. Please ask interval sizes which do not exist on the tables. On the choice of Europe connection system, letter "E" is added at the end of the complete tool code. Such as C10501E.

Combined Skive-Burnishing Tools

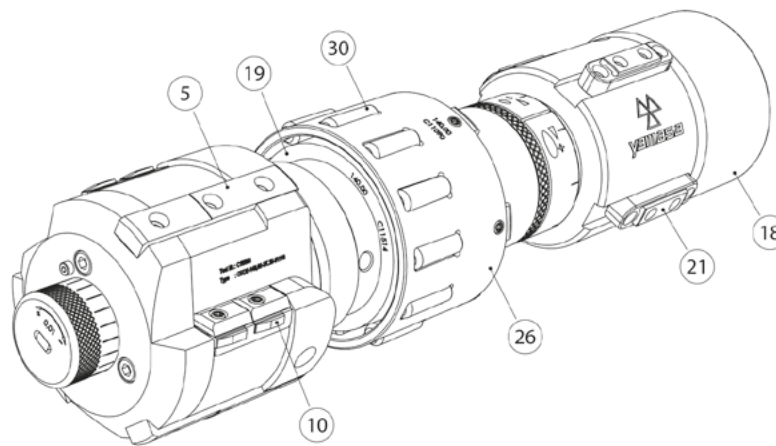

- 5- Guide pad
- 10- Cutting insert
- 18- Shank
- 19- Cone
- 21- Support pad
- 26- Cage
- 30- Roller

Attainability

Tolerance	up to H7
Circle regularity	up to 0,01 mm
Roughness	Ra<0,1 / Rz<1µm

Recommended machining parameters

Dia.Range	Revolution	Coolant flow	Torque	Dia.Range	Revolution	Coolant flow	Torque	Feeding (mm/rev)	Cutting depth (Ø-mm)	Motor power (kW)
Ø-mm	rev/min	L/min	Nm	Ø-mm	rev/min	L/min	Nm			
140 - 149	430 (max.650)	450 - 600	250	160 - 169	380 (max.570)	510 - 680	285	3,5 (max.4)	1 (max.3 opt.)	
150 - 159	400 (max.600)	480 - 640	270	170 - 179	360 (max.540)	540 - 720	300	40 - 50		

Product selection

CEOS tool selection				Spare part selection											
Complete tool		Connection system		Roller		Cutting insert		Guide pad		Support pad		Cone		Cage	
Ø-mm	Code	International	Europe	Code	Pc	Code	Pc	Code	Pc	Code	Pc	Code	Pc	Code	Pc
140,00	C10666	IR118 BTA Female	ER118 BTA Female	C11888	14	C11884	6	C11778	3	C11882	4	C11514	1	C11090	1
145,00	C10674											C11522		C11198	
149,00	C10680											C11528		C11104	
150,00	C10682											C11530		C11106	
155,00	C10690											C11538		C11114	
160,00	C10698											C11546		C11122	
165,00	C10706											C11554		C11130	
169,00	C10713											C11561		C11137	
170,00	C10715											C11563		C11139	
175,00	C10723											C11571		C11147	
179,00	C10729	C11577	C11553												

How to order | Order samples

It is enough to inform the code and quantities of the product you wish to order. For example C11883 x 8 pc. Please ask interval sizes which do not exist on the tables. On the choice of Europe connection system, letter "E" is added at the end of the complete tool code. Such as C10501E.

✓ Achievable surface roughness Rz<1µm / Ra<0,16 µm

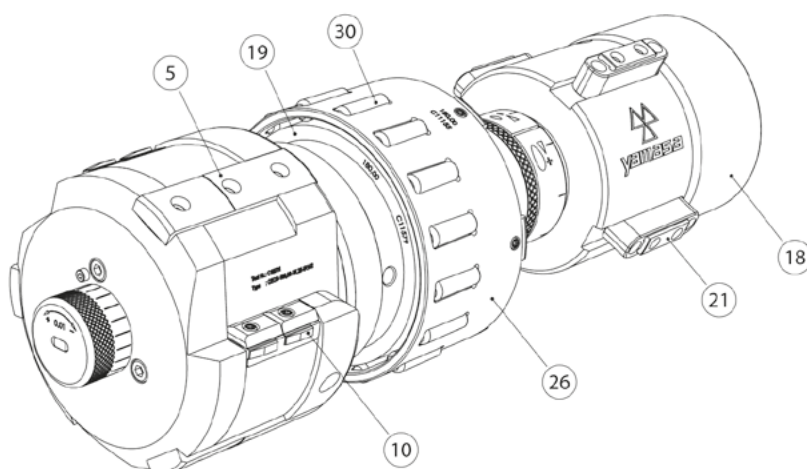
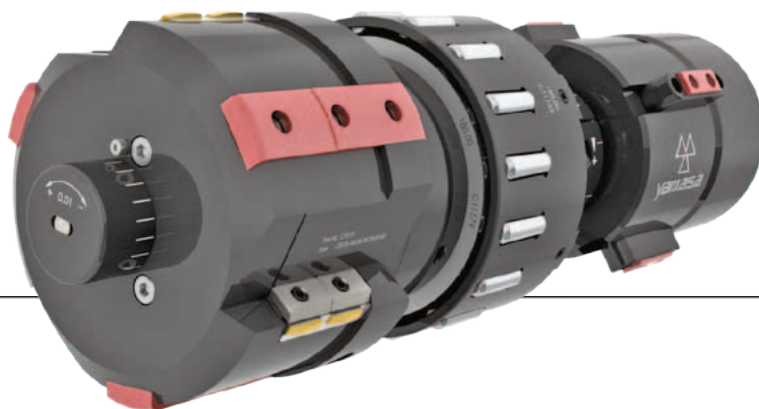

- 5- Guide pad
- 10- Cutting insert
- 18- Shank
- 19- Cone
- 21- Support pad
- 26- Cage
- 30- Roller

Attainability

Tolerance	up to H7
Circle regularity	up to 0,01 mm
Roughness	Ra<0,1 / Rz<1µm

Recommended machining parameters

Dia.Range	Revolution	Coolant flow	Torque	Dia.Range	Revolution	Coolant flow	Torque	Feeding (mm/rev)	Cutting depth (Ø-mm)	Motor power (kW)
Ø-mm	rev/min	L/min	Nm	Ø-mm	rev/min	L/min	Nm	4 (max.5)	1 (max.3 opt.)	40 - 50
180 - 184	350 (max.520)	550 - 740	310	190 - 199	320 (max.480)	600 - 800	335			
185 - 189	340 (max.510)	570 - 760	320	200 - 209	310 (max.460)	630 - 840	350			

Product selection

CEOS tool selection				Spare part selection											
Complete tool		Connection system		Roller		Cutting insert		Guide pad		Support pad		Cone		Cage	
Ø-mm	Code	International	Europe	Code	Pc	Code	Pc	Code	Pc	Code	Pc	Code	Pc	Code	Pc
180,00	C10731	IR142 BTA Female	ER142 BTA Female	C11888	16	C11884	6	C11779	3	C11882	4	C11579	1	C11155	1
185,00	C10739											C11587		C11163	
190,00	C10747											C11595		C11171	
195,00	C10755											C11603		C11179	
199,00	C10762											C11610		C11186	
200,00	C10763											C11611		C11187	
205,00	C10772											C11620		C11196	
209,00	C10778											C11626		C11202	

How to order | Order samples

It is enough to inform the code and quantities of the product you wish to order. For example C11883 x 8 pc. Please ask interval sizes which do not exist on the tables. On the choice of Europe connection system, letter "E" is added at the end of the complete tool code. Such as C10501E.

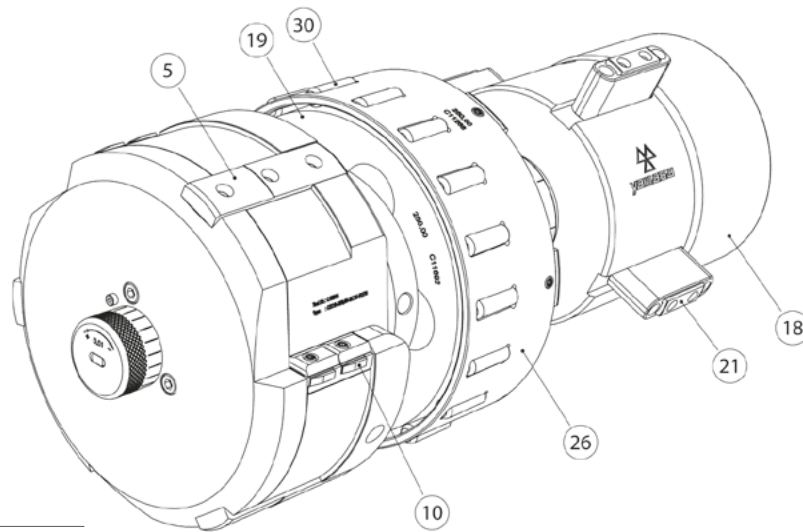

- 5- Guide pad
- 10- Cutting insert
- 18- Shank
- 19- Cone
- 21- Support pad
- 26- Cage
- 30- Roller

Attainability

Tolerance	up to H7
Circle regularity	up to 0,01 mm
Roughness	Ra<0,1 / Rz<1µm

Recommended machining parameters

Dia.Range	Revolution	Coolant flow	Torque	Dia.Range	Revolution	Coolant flow	Torque	Feeding (mm/rev)	Cutting depth (Ø-mm)	Motor power (kW)
Ø-mm	rev/min	L/min	Nm	Ø-mm	rev/min	L/min	Nm			
210 - 229	280 (max.420)	690 - 920	380	250 - 269	240 (max.360)	810 - 1080	445	4 (max.5)	1 (max.3 opt.)	
230 - 249	260 (max.390)	750 - 1000	410	270 - 300	210 (max.320)	900 - 1200	490	40 - 50		

Product selection

CEOS tool selection				Spare part selection											
Complete tool		Connection system		Roller		Cutting insert		Guide pad		Support pad		Cone		Cage	
Ø-mm	Code	International	Europe	Code	Pc	Code	Pc	Code	Pc	Code	Pc	Code	Pc	Code	Pc
210,00	C10780	IR178 BTA Female	ER178 BTA Female	C11888	18	C11884	6	C11779	3	C11882	4	C11628	1	C11204	1
215,00	C10788											C11636		C11212	
220,00	C10796											C11644		C11220	
225,00	C10804											C11652		C11228	
230,00	C10811											C11659		C11235	
235,00	C10820											C11668		C11244	
240,00	C10828											C11676		C11252	
245,00	C10836											C11684		C11260	
250,00	C10844											C11692		C11268	
260,00	C10859											C11707		C11283	
270,00	C10876											C11724		C11300	
280,00	C10892											C11740		C11316	
290,00	C10908											C11756		C11332	
300,00	C10924											C11772		C11348	

How to order | Order samples

It is enough to inform the code and quantities of the product you wish to order. For example C11883 x 8 pc. Please ask interval sizes which do not exist on the tables. On the choice of Europe connection system, letter "E" is added at the end of the complete tool code. Such as C10501E.

Skive & Roller Burnishing Tools

Application

CX type skiving tools machine the hydraulic cylinders in two different operation with CX-D type roller burnishing tools. In first operation, CX skiving tool skive the cylinder; in the second operation, CX-D tool roller burnish the surface.

The tools are retracted after process and rapidly pullback without damaging the surface.

Depending upon cylinder, process result H7 - H8 diameter allowance and also the surface quality of $R_z < 1 \mu\text{m}$ ($R_a < 0,16 \mu\text{m}$) are obtained. Short process time provides time savings.

Tools have precise diameter adjustment. Spare parts can be changed easily. The skiving tool's inserts can be changed without disassemble the knives. The tools can be connected and removed quickly.



*CX-R Skiving tool
For short and long cylinders*



*CX-CS Skiving tool - internal coolant
For used lathe machines and short cylinders*



*CX-D Roller burnishing tool
For short and long cylinders
internal or external coolant*

CX-R Processing properties and parameters

Used machines	Deep hole drilling machines
Processing length	$\leq 20 \text{ m}$
Circumferential speed	150 - 300 m/min.
Feed rate	1 - 5 mm/rev.
Attainability tolerance	up to H7
Attainability circle regularity	up to 0,01 mm
Attainability roughness	$R_z = 5 - 30 \mu\text{m}$
Coolant	Oil or emulsion

CX-CS Processing properties and parameters

Used machines	CNC-universal lathe, machining centers
Processing length	$L/\varnothing \leq 15$
Circumferential speed	150 - 300 m/min.
Feed rate	1 - 5 mm/rev.
Attainability tolerance	up to H7
Attainability circle regularity	up to 0,01 mm
Attainability roughness	$R_z = 5 - 30 \mu\text{m}$
Coolant	Oil or emulsion

CX-D Processing properties and parameters

Used machines	Deep hole drilling, CNC-universal lathe, machining centers
Processing length	$\leq 20 \text{ m}$
Circumferential speed	max. 250 m/min.
Feed rate (per roller)	0,05 - 0,3 mm/rev.
Attainability tolerance	up to H6
Attainability circle regularity	up to 0,001 mm
Attainability roughness	$R_z < 1 / R_a < 0,16 \mu\text{m}$
Coolant	Oil or emulsion

Multiple Head Burnishing Tools



Application

YAMASA UX type tools can burnish two different hole sizes at the same time. Beside of this, tools are used for the aim of providing a precision measurement and surface quality by keeping axiality. The tools provide as well as surface hardness and calibration (measurement accuracy) beside of the burnishing. The tools provide time saving through a high processing power and speed and this is a motive to prefer for the serial production.

Machining parameters

Circumferential speed	max.250 m/min.
Feed rate	0,10 - 0,30 mm/rev. per roller
Pre-machining roughness	Rz = 5 - 20 μ m
Pre-machining	Reaming or lathe
Coolant	Oil or emulsion

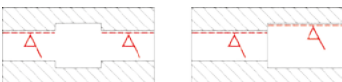

✓ Achievable surface roughness
Rz < 1 μ m / Ra < 0,16 μ m



Technical features and advantages

- The surfaces in quality of Rz < 1 μ m (Ra < 0,16 μ m) can be obtained.
- With same setting it can burnish till H8 hole allowance.
- It is capable to burnish all kinds of metallic materials up to the tensile strength of 1400N/mm² and to the hardness 42-45 HRC.
- Used on universal and CNC Controlled lathe machines, machining centers, milling, drilling etc. machines and also production centers and machines which controlled manual.
- Roller burnishing force can be adjusted, so it is possible to achieve high quality and standard roughness values.
- Diameter adjustments are independent from each other.
- During the operation, the tool or workpiece rotate.
- Roller burnishing of shoulders and other edges is possible up to the end.
- The tool is automatically retracted for do not damage the surface while pulling back .
- It is easy to change the spare part.
- Short process time, provides time saving.
- It removes the second or third tool, machine and personnel requirements.
- It is enough a few lubrication (oil or emulsion).
- It does not make sawdust.

Tool structure

UX type tools consist of a precision body which is special designed and roller head. The bodies of the tools have a special mechanism which enables to make adjustment independent from each other of the roller heads. The roller head consists of cage, cone and rollers. Roller head is specially designed according to workpiece measurements. According to the preference, shank is delivered as morse taper or cylindrical.

Rolling length

Rolling length and step increment are designed specially according to workpiece dimensions. While machining the workpiece, the roller heads of this tools which remove the plenty of tool using and provide time saving are designed to machine max. 3 steps.

Roller Burnishing Machines

Application

YAMASA MXM type machines are used for the aim of burnishing the cylindrical stepped and plain shafts. The machine provides as well as surface hardness and low rate calibration (measurement accuracy) beside of burnishing. Because of the high processing power and speed ability, it provides time saving. These are the preference causes for the serial production.

Technical features

YAMASA MXM roller burnishing machines can process the cylindrical shafts up to H8 tolerances with a single adjustment. These machines are capable to process all kinds of metallic materials with 1400 N/mm² tensile strength and hardness up to max. 42-45 HRC. Super finish surfaces up to Ra= 0,02 µm can be obtained.

With MXM type burnishing machines, part feeding and tolerance adjustment can be done automatically. The machine takes the workpiece and then removes out after the burnishing process is completed. The machine has full automatic specifications. It is capable to achieve a rapid production in order to the automatic feeding system. It can be integrated to each production line for every kind of serial production. As well as automatic loading system can be integrated.

Desing and function

MXM roller burnishing machines are capable to process any kind of diameter between Ø3-Ø40 mm by changing the roller heads. One roller head is used for each nominal diameter. Each roller head has an adjustment capacity of 0,5 mm. The nominal diameter of the roller head can be adjusted with the tolerance between -0,40 and +0,10.

Advantages

- It is capable to achieve a rapid and serial production.
- Saves time, money and energy.
- The roller heads can be replaced easily and rapidly.
- A precision and fast adjustment can be done through the adjustment mechanism.
- No sawdust and residues occur.

MXM Models, properties and parameters

MXM Models	DVH-1	DVH-2	DPH-1	DPH-2	NC-1	NC-2
Working range (Ø-mm)	1-20/25*	1-40	1-20/25*	1-40	1-20/25*	1-40
Control panel	Dijital		Digital		Numarical control(NC)	
Coolant system	Manuel or spraying		Continuously lubrication-internal coolant			
Coolant	Oil		Oil or emulsion			
Coolant tank capacity	-		30 Liter (including filter)			
Electric connection	400 V 50 Hz					
Processable surfaces	Plain/stepped shafts					
Proccesing length	Unlimited					
Revolution	0-1400 rev./min (with speed control)					
Feed rate	0,9 - 3 mm/rev.					
Pre-machining rough.	Rz= 5 - 20 µm					
Burnishing allowance	up to 0,02 mm					

* Optional

MXM DVH-1
Roller burnishing machine
Manuel lubrication or
minimal lubrication spraying system

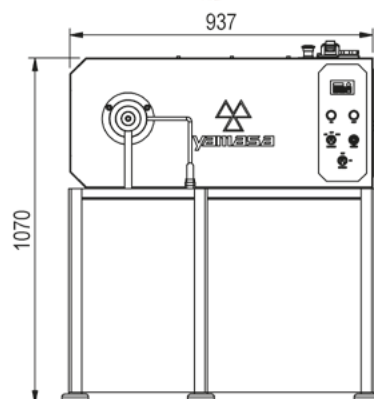
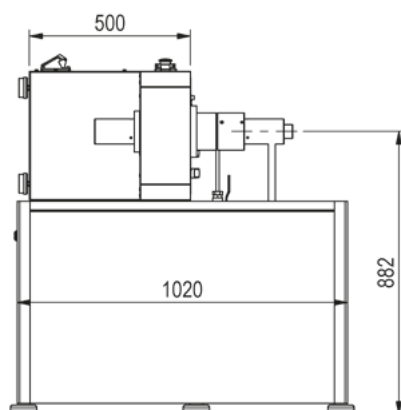

MXM DPH-1
Roller burnishing machine
internal coolant system

Sample of applications

Shock absorber shafts, pneumatic cylinder shafts, HDD shafts, coil, powered tooth brush drive shafts, printer guide shafts, air hammer parts, air condition shafts, pump shafts, motor shafts, optical drum for copying machine, wire etc.

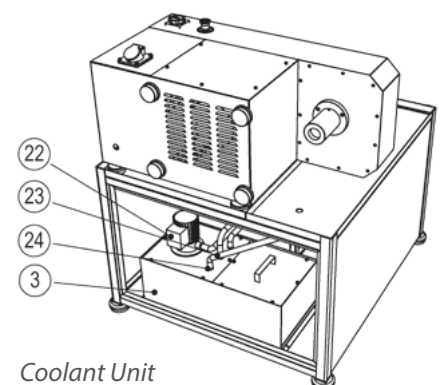

Coolant Unit

MXM Series | For cylindrical shafts

Roller Burnishing Machines



MXM Multi series

For processing piston rods and long type shafts



MXM NC-2
Roller burnishing Machine
internal coolant system